



**CITY OF ELK GROVE**

**Citywide Design Guidelines**

**October 2021 IWG DRAFT**



# TABLE OF CONTENTS

## CHAPTER 1

**INTRODUCTION..... 1**

**1.A PURPOSE AND INTENT ..... 3**

**1.B BACKGROUND..... 3**

**1.C ORGANIZATION AND USE .....4**

## CHAPTER 2

**ADMINISTRATION..... 5**

**2.A DESIGN REVIEW .....7**

**2.B DESIGN REVIEW REQUIREMENT .....7**

**2.C DESIGN REVIEW APPROVING AUTHORITY .....8**

**2.D APPLICABILITY TO ADOPTED AREA PLANS AND PENDING APPLICATIONS.....8**

**2.E THE DESIGN REVIEW PROCESS.....8**

**2.F DESIGN REVIEW COMPLETION .....9**

## CHAPTER 3

**SINGLE FAMILY RESIDENTIAL DEVELOPMENT ..... 11**

**3.0 INTRODUCTION.....13**

**3.1 LAND PLANNING FOR SUBDIVISION MAPS .....14**

        A. HOUSING TYPES AND NEIGHBORHOOD CHARACTER ..... 15

- B. CIRCULATION SYSTEMS ..... 16
- B.I. STREET DESIGN ..... 16
- B.II. NON VEHICULAR CIRCULATION ..... 17
- C. WALLS ..... 19
- D. OPEN SPACE AND PARKS ..... 20
- E. LANDSCAPE: STREETScape AND INDIVIDUAL LOTS ..... 21
- E.I. ARTERIAL AND COLLECTOR STREETS ..... 21
- E.II. RESIDENTIAL STREETS AND INDIVIDUAL LOTS ..... 22
- F. LIGHTING ..... 23
- G. UTILITY/TRASH RECEPTACLE SCREENING ..... 24

**3.2 ARCHITECTURE FOR MASTER HOME PLANS .....25**

- A. STREETScape VARIETY THROUGH RESIDENTIAL DESIGN..... 26
- A.I. FLOOR PLAN TYPES ..... 26
- A.II. VARYING DESIGN ELEMENTS CREATE INTEREST AND VARIETY ..... 28
- A.III. BULK AND MASS ..... 28
- B. COLOR AND MATERIALS ..... 30
- C. ARCHITECTURAL STYLES ..... 31
- D. GARAGE PLACEMENT ..... 48
- D.I. FRONT LOADED GARAGES ..... 48
- D.II. ADDITIONAL GUIDELINES FOR THREE- OR MORE- CAR GARAGE DESIGN ..... 51
- D.III ALLEY LOADED GARAGES ..... 53

**CHAPTER 4**

**MULTI-FAMILY RESIDENTIAL DEVELOPMENT ..... 55**

**4.0 INTRODUCTION .....57**

**4.1 SITE DESIGN .....58**

- A. BUILDING PLACEMENT & SITE ORGANIZATION ..... 58



B. OPEN SPACE AND AMENITIES .....	60
C. ACCESS AND CIRCULATION.....	62
D. PARKING .....	63
E. LANDSCAPING.....	64
E.I. LANDSCAPE CORRIDORS .....	64
E.II. PERIMETER LANDSCAPE.....	65
E.III. INTERNAL LANDSCAPE .....	66
F. LIGHTING OF PARKING AREAS, DRIVE AISLES, AND PEDESTRIAN WALKWAYS .....	67
G. TRASH ENCLOSURES AND UTILITIES .....	68
H. FENCING .....	69

## **4.2 ARCHITECTURE FOR MULTI-FAMILY DEVELOPMENT .....70**

A. ARCHITECTURAL STYLE AND DESIGN.....	70
B. MASSING, SCALE, AND FORM .....	71
C. MATERIALS AND FINISHES.....	73
D. BUILDING ENTRIES .....	75
E. BUILDING LIGHTING .....	76
F. SIGNAGE.....	77
G. ADDITIONAL GUIDELINES FOR VERTICALLY MIXED-USE BUILDINGS.....	78

## **CHAPTER 5**

### **NON-RESIDENTIAL DEVELOPMENT.....81**

#### **5.0 INTRODUCTION.....83**

#### **5.1 SITE PLANNING FOR NON-RESIDENTIAL DEVELOPMENT .....84**

A. BUILDING PLACEMENT & SITE ORGANIZATION .....	84
B. CIRCULATION .....	86
B.I. VEHICULAR CIRCULATION .....	86
B.II. PEDESTRIAN CIRCULATION.....	87

B.III. ALTERNATIVE MODES .....	88
C. PARKING.....	89
C.I. AUTOMOBILE .....	89
C.II. ALTERNATIVE MODES .....	90
D. LANDSCAPE.....	91
D.I. STREETSCAPE + PEDESTRIAN WALKWAYS.....	91
D.II. PARKING LOT LANDSCAPE .....	92
D.III. PROJECT ENTRY LANDSCAPE .....	94
D.IV. LANDSCAPE FOR PLAZAS AND COMMUNITY SPACES .....	94
D.V. LANDSCAPE FOR BUILDING EDGES .....	96
D.VI. WALLS/FENCING .....	97
E. TRASH, MECHANICAL EQUIPMENT, LOADING AND SERVICE AREAS .....	98
E.I. TRASH AND RECYCLING .....	98
E.II. MECHANICAL/UTILITY PLACEMENT .....	99
E.III. LOADING AND SERVICE AREAS.....	100
H. LIGHTING .....	101
I. SITE AMENITIES .....	102
I.I. PLAZAS.....	102
I.II. SITE FURNITURE .....	103
J. ADDITIONAL DESIGN GUIDELINES FOR SPECIFIC TYPES OF NON-RESIDENTIAL DEVELOPMENT.....	104
J.I. RETAIL COMMERCIAL CENTERS.....	104
J.II. BUSINESS PARKS.....	106
J.III LIGHT INDUSTRIAL .....	108
<b>5.2 ARCHITECTURE FOR NON-RESIDENTIAL DEVELOPMENT .....</b>	<b>109</b>
A. ARCHITECTURAL STYLE AND CHARACTER.....	109
B. MASS, SCALE, AND FORM.....	111
C. ARTICULATION, FENESTRATION AND WINDOWS.....	113
D. ENTRIES AND DOORWAYS .....	114

E. MATERIALS AND FINISHES.....	115
F. SIGNAGE.....	116
G. BUILDING LIGHTING.....	117
H. ADDITIONAL GUIDELINES FOR SPECIFIC TYPES OF NON-RESIDENTIAL DEVELOPMENT .....	118
H.I. COMMERCIAL CENTERS .....	118
H.II. BIG BOX RETAIL .....	119
H.III. LIGHT INDUSTRIAL/BUSINESS PARKS .....	121





**CHAPTER 1**  
**Introduction**



*The Citywide Design Guidelines implement the goals and policies of the General Plan and expand on the basic development standards of the Zoning Code. Specifically, the Guidelines implement the General Plan land use policies and strategies relative to urban design, pedestrian circulation, community and neighborhood identity, residential, commercial, and industrial project design. The Design Guidelines also supplement the design provisions of adopted Special Planning Areas and Specific Plans where the existing document is silent.*

## 1.A PURPOSE AND INTENT

The purpose of design review in the City of Elk Grove is as follows:

- To promote the orderly and harmonious growth of the City.
- To encourage development in keeping with the desired character of the City.
- To ensure physical, visual, and functional compatibility between uses.
- To help prevent the depreciation of land values by ensuring proper attention is given to site and architectural design.

This permit is intended to provide a process for consideration of development proposals in which the site, architectural, and overall project design are substantially improved by, and provides a City benefit with, the consideration of modifications to the conventional development regulations of the underlying zoning district under special circumstances. However, the flexibility does not apply to use of the land in that only those uses permitted within the underlying zoning district are allowed. These Design Guidelines are intended to provide design professionals, property owners, residents, staff, and decision-makers a clear understanding and

a common interpretation of the City's expectations for the planning, design and review of development proposals in Elk Grove

## 1.B BACKGROUND

Elk Grove is a geographically and ethnically diverse, family-oriented community with an exceptional quality of life. The City is known for having a range of housing options at all levels, an award-winning school district, a historic district, and a first-rate parks system. Elk Grove has a prosperous business community with an entrepreneurial spirit that boasts a variety of shops and services. The City will continue to promote a high quality of life and diverse living options, while at the same time achieving a strengthened identity within the region and providing greater recreational opportunities, better access to community facilities, improved lifestyle amenities, and expanded employment opportunities.

The City of Elk Grove's current Citywide Design Guidelines were adopted by the Elk Grove City Council in phases in 2003, 2004, and 2007. Development applications over the last 15 years have been evaluated based on consistency with the adopted Design Guidelines. Since the adoption of the Design Guidelines, the City has matured, a broad range of

development has occurred in all areas of the City, and design trends and practices have evolved.

Recognizing the limitations of the existing Design Guidelines, the City, in 2019, initiated a comprehensive update to the Citywide Design Guidelines as a City Council Strategic Imperative. The goal of this effort was to enhance standards for community design while encouraging creativity and recognizing the unique characteristics of distinct neighborhoods while maintaining housing affordability. The update is intended to address the market and design demands of the day while maintaining flexibility to accommodate future trends without compromising the vision and the character of Elk Grove.

As a part of the update, the residents, business owners, and members of the development community participated in workshops, community meetings, stakeholder interviews and community focus group meetings. Their input is reflected in these Guidelines, which are intended to be clear and concise, without limiting creative design solutions.

## 1.C ORGANIZATION AND USE

The Citywide Design Guidelines will be used in the review of projects within the City of Elk Grove. To facilitate ease of use, this document is organized into different sections based on the proposed type of project. There are separate sections for Single-family Residential Development (Subdivision Maps and Master Home Plans), Multi-family Residential Development, and Non-residential Development. Within each section, there are design criteria for various aspects of site and building design. Each section is structured with an introduction to desirable design concepts, followed by guidelines that reiterate design objectives and establish provisions and options to ensure implementation of desired design concepts. Guidelines are listed in the form of recommended/encouraged provisions (should), specific solutions/mandatory requirements (shall), design targets through representative sample, or a menu of design solutions from which to choose. Guidelines also include incentive-based provisions to encourage exceptional design. This approach results in a greater measure of predictability to the Design Review process, while maintaining flexibility and the option for creative design solutions.

The Design Guidelines shall be used in conjunction with other documents adopted by the City that contain goals, development parameters, and more specific regulations relative to a particular type of development. In other words, development projects shall also comply with applicable provisions of the City's General Plan and all applicable sections of the Municipal Code, Specific Plans, Special Planning Areas, and other adopted standards or plans. References to applicable provisions are made throughout the Guidelines.

The City of Elk Grove has adopted several Specific Plans and Special Planning Areas (Area Plans) with development review processes and/or Design Guidelines for development within specified boundaries. The Citywide Design Guidelines will apply in those areas if the Specific Plan/Area Plans are silent or defer to the Citywide Design Guidelines.





**CHAPTER 2**  
**Administration**



*This section describes the design review process. The following sections describe the type of projects, the reviewing authorities and the anticipated process for design review.*

## 2.A DESIGN REVIEW

Design Review is a discretionary process established to determine if a development project complies with applicable Design Guidelines and to ensure consistency with the General Plans goals and policies for high-quality design. The purpose of the design review process is to promote the orderly and harmonious growth of the City; to encourage development in keeping with the desired character of the City; to ensure physical, visual, and functional compatibility between uses; and to help prevent the depreciation of land values by ensuring proper attention is given to site and architectural design. This permit is intended to provide a process for consideration of development proposals in which the site, architectural, and overall project design are substantially improved by, and provides a City benefit with, the consideration of modifications to the conventional development regulations of the underlying zoning district under special circumstances.

## 2.B DESIGN REVIEW REQUIREMENT

- The Elk Grove Municipal Code sets forth the requirements for when Design Review is required for Projects. The individual design review processes the associated project types and exemptions are listed in the Section 23.16.080 of the Municipal Code. The following Citywide Design Guidelines apply to the following projects types:
- Single-family Residential Subdivision Maps.
- Master Home Plans for Single-family Residential Subdivisions.
- Multi-family Residential Development.
- Non-residential Development (e.g., commercial, office, industrial, and public/quasi-public development).

## 2.C DESIGN REVIEW APPROVING AUTHORITY

The designated approving authority (Development Services Director, Zoning Administrator or the Planning Commission) for design review is listed in Section 23.14.050, Table 23.14-1 (Approval Authority) of the City of Elk Grove Municipal Code (EGMC). For any design review process not specifically identified in subsection B in Section 23.16.080 of the EGMC of the Zoning Code, the Planning Commission shall be the designated approving authority. In some cases, when a project includes a legislative action, a design review approval may be decided by the City Council

## 2.D APPLICABILITY TO ADOPTED AREA PLANS AND PENDING APPLICATIONS

Most of the adopted Specific Plans and Special Planning Areas (Area Plans) in Elk Grove include a Design Review process and some of the plans include Design Guidelines. The Citywide Design Guidelines will apply in those areas if the Specific Plan/Area Plans are silent or defer to the Citywide Design Guidelines.

The Design Review process and corresponding Citywide Design Guidelines herein shall apply to all applications, including pending applications identified in Section 23.16.080 (B) of the EGMC that are not otherwise exempt. Applications are no longer pending once the appeal period on the City's entitlement action has expired or the appeal process has been fully exercised.

For single-family residential development, new Design Review will not be required for approved Tentative Subdivision Maps, but will apply to Master Home Plans not approved prior to the effective date of the updated Design Review Ordinance.

## 2.E THE DESIGN REVIEW PROCESS

The Design Review process is the application, review, and determination of compliance with the provisions of the Design Review Ordinance (Section 23.16.080) and applicable Design Guidelines herein.

If the Design Review determination by the Development Services Director on an application for a particular project is appealed to the Planning Commission, the appeal action by the Planning Commission is final, unless that decision is appealed to the City Council.

Minimum Design Review application submittal requirements are listed on the individual Design Review application forms provided by Development Services Planning Staff. Applications shall be submitted to the Planning Division on appropriate forms based on the scale, type and the level of approvals sought. Applications will not be accepted without payment of required fees.

## 2.F DESIGN REVIEW COMPLETION

The Design Review process is tentatively complete when the approving authority takes action to approve, conditionally approve, or deny the application. However, implementation of the action (e.g., site improvement plans, building permits) may not occur until the required ten-day appeal period has expired.

This page is intentionally left blank

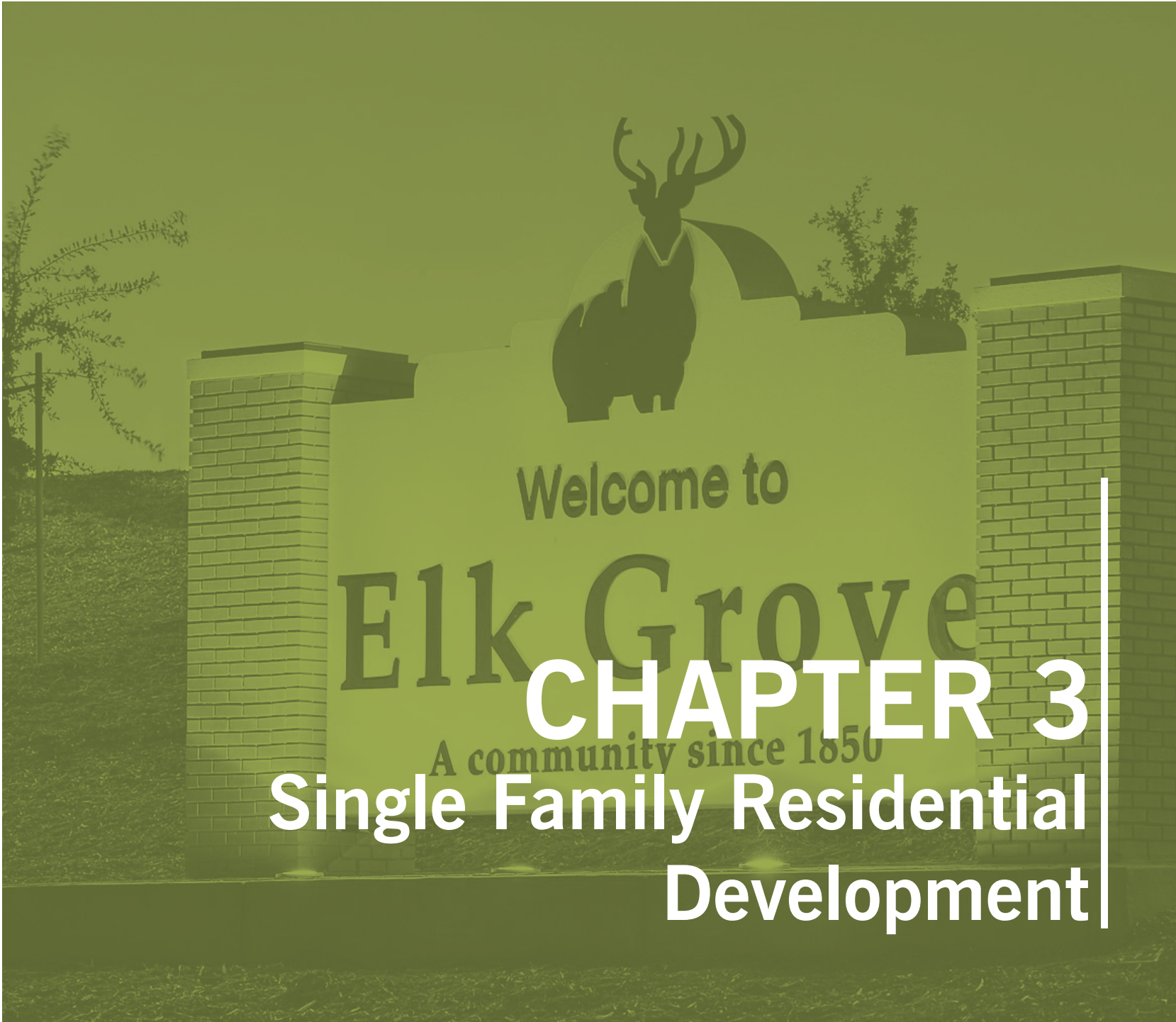

**CHAPTER 3**  
**Single Family Residential**  
**Development**





## 3.0 INTRODUCTION

*This chapter is divided into two main sections: (3.1) Land Planning for Subdivision Maps, and (3.2) Architecture for Master Home Plans. Each section introduces the City's Design Guidelines applicable to Design Review applications for single family residential subdivision maps and master home plans.*

*Within the City of Elk Grove, Design Review is required for Single-family Residential Subdivision Maps. Design Review applications for Subdivision Maps shall be processed and considered in conjunction with the Tentative Subdivision Map application.*

*The Design Guidelines reiterate specific objectives and establish provisions and options to ensure implementation of desirable design concepts. Guidelines herein are intended to supplement the Elk Grove Municipal Code, and other adopted plans and policies as applicable.*



## 3.1 LAND PLANNING FOR SUBDIVISION MAPS

*Neighborhoods are defined as a place with a character and a boundary. Neighborhoods are the strategic building blocks of overall community development. For the purposes of the land planning Guidelines the neighborhood definition would apply to master plans and to individual subdivisions that are not part of a larger master plan – either infill or greenfield.*

*The City recognizes and values the diversity of its existing neighborhoods. This section is not intended to dictate a single solution to every type of neighborhood development application. Rather, this section of the Guidelines introduces good neighborhood design concepts and general provisions that can be applied to varying degrees within the projects of different scales proposed within the city. Though the projects may be of different scales the goal of the Design Guidelines is to promote:*

- ***A balanced mix of land uses including housing, working, schooling, and commercial services to promote a cohesive pattern of development that is compact and sustainable.***
- ***Appropriate scale and character that promotes walkability and opportunities for social interaction.***
- ***Housing diversity to address current and future demographic trends with a variety of housing types, sizes, and densities.***
- ***Multi-modal connectivity that promotes all forms of transportation both within the neighborhood and surrounding neighborhoods and uses.***
- ***Access to open space. Open space may be active or passive and may be programmed as parks or natural preserved open space.***
- ***Responsiveness to existing features by incorporation of natural features in the design of the neighborhood.***
- ***Utilization of best management practices, such as Low Impact Development, which promotes conservation of resources and sustainable development practices.***



*Incorporate compact development types (for example, small lot housing)*



*Incorporate innovative housing types into future trends (for example, small lot alley loaded homes)*



## A. HOUSING TYPES AND NEIGHBORHOOD CHARACTER

The City allows for a variety of single-family residential development ranging from large rural residential to medium, and small lot residential developments. Recognizing the unique design characteristics of large rural residential, the Design Guidelines, where applicable, specifically address certain issues pertaining to these housing types. For the purposes of these Guidelines, rural residential subdivisions are defined as developments with lot sizes greater than or equal to two acres and small lot subdivision are defined as developments with lot sizes less than 4000 square feet.

The richness and vitality of a city is reflected in the diversity of its neighborhoods. Elk Grove incorporates a variety of distinct neighborhoods to be preserved and enhanced as new development and infill projects occur. As new development occurs, it is crucial not to lose the qualities that define the character of the distinct neighborhoods.

- Proposed development within neighborhoods shall be consistent with the development standards of the underlying zoning district. Deviations from the development standards if required are permitted through the Design Review Process.
- The City encourages the design of single-family residential neighborhoods with a mix of densities and lot sizes to create diversity of housing products.
- For developments within or adjacent to established neighborhoods, identifiable and distinguishing neighborhood characteristics should be preserved and enhanced. Examples of such characteristics include distinct architectural building styles, unique streetscapes, network of public spaces and open space corridors.
- The City encourages neighborhood design that incorporates existing natural features of the property. Examples of natural features include, but are not limited to, creeks, drainage canals, riparian habitats, and significant mature vegetation.
- Improvements at subdivision entrances provide the initial neighborhood identity from surrounding areas. Both primary and secondary entrances to the neighborhood should be designed to reflect the neighborhood character. Emphasis should be placed on the design of primary entrances. At a minimum, entry areas should include sufficient space to accommodate an organized landscape planting theme. Other potential improvements include enhanced pavement at the intersections, theme walls and/or monument signage, water features, public



*Example of improvement at an subdivision entrance*

art, pedestrian amenities such as seating or enhanced walkways/trellis features, and lighting.

## B. CIRCULATION SYSTEMS

The City encourages a circulation system designed as an integrated network of facilities accommodating all forms for transportation choices, such as pedestrians, bikes, scooters, vehicles, transit etc. Appropriately designed street systems promote multi-modal connectivity both within and between the neighborhoods.

- Neighborhoods shall be designed with an interconnected street system that will blend well into the existing street system, diffuse traffic within the neighborhood, and improve vehicle circulation to and through the site.
- The proposed street system shall be designed as an extension of the existing street network that minimizes the barriers within and between neighborhoods.
- Neighborhoods shall be designed with a local hierarchy of roads that incorporates streets providing direct and indirect connections within a neighborhood and integrates with surrounding street networks and neighborhoods.
- Residential streets may be designed with linear/grid pattern, curvilinear, and/or short cul-de-sac streets.

### B.I. STREET DESIGN

- New residential streets shall comply with the City's street standards as outlined in Title 22 of the Municipal Code.
- Residential streets (local and collector) shall be designed for low speeds and low volumes by utilizing the smallest possible street design to accommodate daily traffic volumes. The intent is to discourage the oversizing of residential streets.
- Alternative designs to improve the aesthetics, pedestrian experience, or circulation are encouraged with the condition that minimum pavement width for both public and private streets shall be consistent with the City's adopted residential street standards. Examples of alternative designs include, but are not limited to, sidewalks separated from the back of curb by a landscape planter strip, landscape medians, tree preservation within the right-of-way, traffic circles, narrow sections/neck downs to slow traffic, and other approved traffic calming devices. Alternative designs shall be reviewed and approved by the designated approving authority. Design provisions and guidelines for alternative street designs include:
  - Where alternative street designs involve landscape medians and/or separated sidewalks with planter strips, the City encourages the use of drought tolerant



*Separated sidewalks on a residential street*



*Example of a bulb-out on a residential street*



*Example of a shared street*



planting and grading/improvement design maximizes runoff into designated planter areas.

- Subdivisions with minimum lot sizes equal to or greater than two acres in size may design residential streets to evoke a rural character e.g., street sections with no sidewalk or curb and gutters or as approved by the Public Work Director.
- Small lot subdivisions may incorporate alternative street designs that reduce sidewalks, utilize stub streets/auto courts, incorporate one-way drive aisles, or other unique design features such as shared streets for higher density development.
- All primary residential streets and collector streets shall be designed with separated sidewalks. To encourage the design and development of separated sidewalks on local residential and primary residential streets, EGMC Section 23.90.020 allows for reduction of minimum front yard and/or street side yard setbacks.

## B.II. NON VEHICULAR CIRCULATION

Non-vehicular circulation should be considered as an important part of the circulation framework that provides the residents with an alternative mobility option and thereby reducing dependency on automobiles. Non-vehicular circulation can be provided and promoted by designing streets as Complete Streets or by providing a complimentary integrated non-vehicular network provides a safe and convenient alternative to the street network.

- Both on-street and off-street bikeways and pedestrian paths (sidewalks) should be incorporated throughout new residential neighborhoods to connect residential areas with schools, parks, neighborhood-serving commercial areas and transit stops.
- Pedestrian and bicycle paths/routes shall provide connections to immediately surrounding roadways, community facilities, and other non-residential uses and open space areas outside the project.
- Gates as entryways into subdivisions are discouraged, as they discourage interaction among neighborhoods. However, when the City approves gated entrances, such entrances shall include separate pedestrian access gates. Gates shall be included at points along the perimeter of the subdivision to provide access to the surrounding arterial street system and easy



*Example of an on-street bike lane*



*Auto Court small lot subdivision*



*Traffic circles are encouraged as a traffic calming tool*

### 3.0 Single Family Residential Development

connectivity to bike trails and routes, transit stops, and adjoining activity areas (e.g., retail centers, parks, open space).

- Sidewalks and pedestrian pathways shall be sized depending on the street classification location and anticipated use.
- To promote the development of a robust city-wide non-vehicular circulation network, neighborhood plans shall be in compliance with the City of Elk Grove's Bicycle, Pedestrian and Trails Master Plan.
- To minimize conflicts between the different transportation modes, special consideration shall be given to the design of street crossings and intersections where collector/primary residential streets intersect, a collector/primary residential street intersects an arterial street, or at access to neighborhood gathering places, such as schools,

parks, and non-residential uses. In order to ensure safe and convenient street crossings, one of the following design improvements listed below, or a combination thereof, shall be incorporated at such locations:

- Use of paint striping and pattern, signage, or lighting to call out and delineate crossings.
- Utilize the smallest curb radii at the intersection and incorporate landscape planters or hardscape at corners to narrow the street section.
- Use of bulbouts at intersections to reduce path of travel between the two sides of the street.
- Use of user-activated flashing lights.
- Use of a bike-box at intersections to reduce conflict with right turn lanes.

- Use of designated mid-block crossings where the intersections are located far apart.
- Use of islands with coordinated/ appropriately timed traffic signals to facilitate crossing of larger streets.
- Use of stamped/colored concrete or other decorative pavers to highlight areas of high pedestrian traffic.
- Use of a raised cross walk as a speed table to visually call attention and slow traffic.
- Other pedestrian improvement that serves as the functional equivalent to the satisfaction of the City.



*Incorporate visual cues for pedestrian crossings such as a change in pavement*



*Utilize bike boxes at intersections to create a safe biking environment*



*Mid-block crossings shall be easily seen from vehicular circulation*



## C. WALLS

Walls along the perimeter of a residential neighborhood are discouraged as they can create a barrier between the neighborhood, the individual buildings and the streetscape. The City encourages front or side-on lots adjacent to local residential and residential collector streets where traffic and noise impacts allow. This orientation contributes to a more aesthetic and pedestrian friendly streetscape. Walls should only be used when required for noise mitigation. When sound walls are found to be necessary, the following guidelines apply:

- Sound walls shall be located behind required landscape corridors. Required landscape corridors are adopted by street type in the City's street improvement standards. The setback shall be improved with landscaping to create a unified streetscape and to soften/screen the appearance of the sound wall.
- Sound walls shall be constructed of brick, concrete, or masonry material.
- Design of sound walls shall include a trim cap and should incorporate pillars or recesses/changes in direction intermittently to avoid long, uninterrupted flat wall planes.
- Where sound walls occur, pedestrian connection from residential neighborhoods to arterial streets and residential collector streets shall be provided. Pedestrian connections shall be

provided between residential lots, along open space areas, or from cul-de-sac's at a minimum spacing of approximately one quarter mile.

Where such openings are provided, the openings shall be a minimum of 20' or twice the height of the walls, whichever is greater. The location of pedestrian connections shall take into consideration desirable, safe, and convenient access to surrounding uses and shall be a part of the pedestrian network in the neighborhood.



*Approved gates into subdivisions shall include a separate pedestrian access gate*



*Example of a sound walls with a trim cap and pillars*

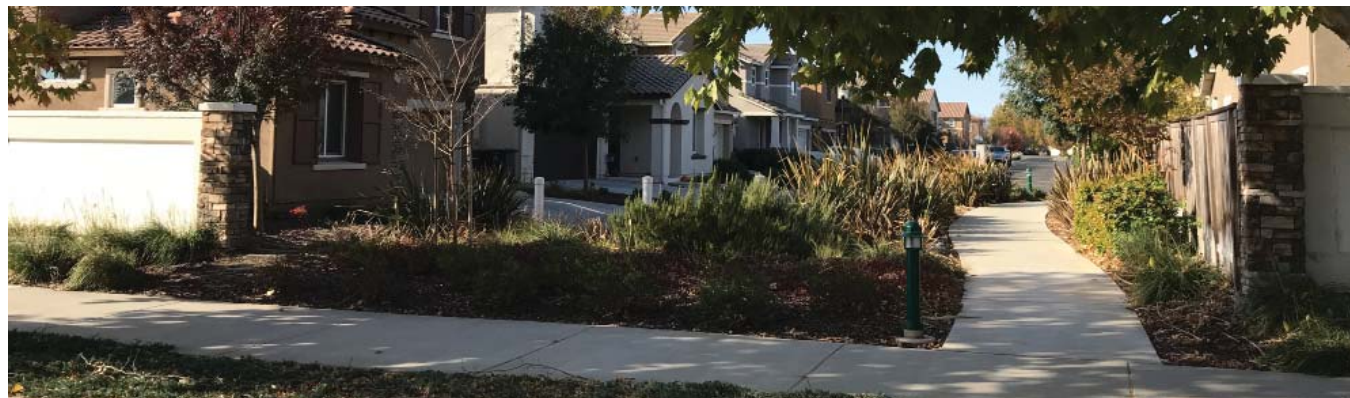

*Sound walls shall include pedestrian connections from arterial streets to residential neighborhoods*



## D. OPEN SPACE AND PARKS

A major feature of the subdivision map/land plan is the system of parks and open space that provide active and passive use, preservation of significant natural features, and linear open space areas connecting complimentary land uses.



*Example of an active and passive use within a park*

- Parks and open space planning shall be consistent with Parks Master Plan and other current plans adopted by the City and Cosumnes Community Services District (CCSD).
- The City encourages the location of parks and other open space amenities within residential neighborhoods so that they are easily accessible by a majority of the residents.
- Where open space areas are located in conjunction with existing natural features, neighborhoods shall be designed to provide safe and convenient access to and visibility of such areas.
- Neighborhood parks within residential neighborhoods shall be oriented towards streets, homes or open spaces. Homes along the park edges should be oriented towards the park. To promote “eyes on the park” homes shall front on or side on to the parks.
- Where homes back on to neighborhoods parks or open space, solid rear yard fencing taller than 3’ is prohibited. Fencing above 3’ shall be open view.
- Special consideration shall be given to screening for nuisance such as headlights from adjacent roadways, or privacy and safety concerns when homes are adjacent to trails/ open space corridors.



*Location of parks should be accessible to a majority of residents*



*Houses shall front on or side on to the park to promote “eyes on the park”*



*Example of homes backing onto neighborhood parks with open view fencing*



## E. LANDSCAPE: STREETScape

As part of land planning, Design Review for subdivision maps shall include conceptual streetscape design for visually, physically, and functionally appealing streetscape throughout the neighborhood. The landscape treatment of streets and homes should enhance surrounding improvements, create a pedestrian friendly environment, and establish year-round and seasonal landscape to soften the appearance of streets and the public realm.



*Street with detached sidewalks shall have trees planted in a single row in the center of the planting strip*

### E.I. ARTERIAL AND COLLECTOR STREETS

Street trees are the primary delineators within the landscape corridor, which aesthetically create rhythm and soften the environment along street corridors. Street trees commonly serve to provide shade, to scale the environment to a pedestrian scale, and to define an image. A dominant scheme of street trees will unify all the elements within the landscape corridor.

- Landscape corridors shall be provided along Principal and Major Arterials, per the Municipal Code. Reductions in the landscape corridor width of arterial/thoroughfare or collector streets to ensure continuity with an existing approved corridor for consistency with the character of an existing corridor may be allowed.
- Street trees shall be planted in a single row, set back a minimum of five feet from the back of curb and concrete sidewalks/driveways. However, for streets with detached sidewalks or planting strips between the sidewalk and the sound wall, trees shall be planted centrally in the planter.
- Accent trees are intended to supplement and enhance the street trees. Accent trees should have distinguishing characteristics (color, shape, texture, flowering pattern) to highlight significant areas within the neighborhood as wayfinding

elements, (e.g., points of entry, pedestrian access points, intersections, transitional areas, bus shelters).

- Both street trees and accent trees should include varieties that provide for screening, canopy, and year-round interest and seasonal character. The tree varieties may be evergreen, deciduous or a combination of both.
- Shrubs and groundcover shall be designed to enhance the character of the neighborhood. Landscape considerations should include visual appeal (e.g., flowers, foliage, form) and function (to maintain vehicle sight, conceal masonry walls, and utilities/equipment).
- Planting material shall include the use of drought-tolerant, indigenous, and native-adapted landscape species.



*Street trees and accent trees should provide screening and canopy*

## E.II. RESIDENTIAL STREETS

On local residential and primary residential streets, street trees are required for aesthetic, shade/ climate control, and pedestrian purposes. Ideally, street tree plantings will create a contiguous tree canopy along the street over time. Depending on street design, the trees may be located in designated planting bays or in the front yard of individual lots.

- A minimum of two trees shall be planted on each single family residential lot fronting on to a street except for lots in zoning districts R8 and above. One of the trees shall be planted near the street (street tree) and the sidewalk and the second tree (accent tree) may be located anywhere in the front yard area. Lots in zoning districts R8 and above are only be required to plant the street tree.
- Where a monolith sidewalk abuts the back of curb, the street tree shall be planted within seven to eight feet from the back of the sidewalk; and where the sidewalk is separated from the back of curb with a planter strip, the street tree shall be planted centrally in the planter area.



Street tree shall be within 7-8 feet from the back of a monolithic sidewalk



STREET TREE

ACCENT TREE



## F. LIGHTING

Lighting along streets and neighborhoods should be compatible in scale and character. The quality and amount of lighting are intended to promote safety and general welfare and promote the preservation of the natural nighttime outdoor environment by regulating artificial lighting.

- Lighting shall be designed and located in accordance with the City of Elk Grove's Improvement Standards.
- Downward directing lighting fixtures with full cut-off shields shall be used to minimize light pollution and protect views of the night sky.
- Street lighting along local streets shall be designed at a pedestrian scale, with a maximum height of fourteen (14) feet.
- As an alternative to street lights, bollard lights or low lights attached to street furniture may be used provided they comply with the City of Elk Grove's Improvement Standards.
- The color of light poles and fixtures shall be same throughout the neighborhood. Changes in hues are allowed. e.g. different shades of the same color



*Use of bollard lights instead of street lights*



*Pedestrian scaled downward directing light fixture*



*Color of light fixtures with changes in hues (example: shades of grey in the above photo) within the same neighborhood*



*Color of light poles shall be consistent throughout the neighborhood*

## G. UTILITY/TRASH RECEPTACLE SCREENING

Adequate space shall be provided for utilities and trash storage areas. .

- Above ground utilities and related equipment shall be screened from direct public view. The screening may be achieved through planting, fencing or screens.
- Fencing shall be constructed of wood, fiber cement or masonry (including stucco).
- Fencing material shall be of the same color as the adjacent residential structure or the fence.
- Planting when used for screening shall include evergreen plant species in order to maintain year-round visual screening.
- All homes on lots smaller than 4000 sf shall provide for storage areas for residential trash receptacles in garages, side or rear yards. Trash storage locations shall be shown on the land plan and/or site plan to ensure effective screening from public rights-of-way on all days except garbage collection days.
- For developments where individual homes do not front on to a street (e.g. cluster developments, alley loaded homes on a paseo) a trash collection plan shall be approved during the design review or tentative map approval process. The trash collection plan shall illustrate

how the trash is collected either from individual homes or from a common location. Based on the trash collection plan, the plan shall include:

- Design of vehicular access-ways (streets, shared driveway or alley) that is approved by the waste collection services for trash collection at individual homes.
- Creation of stacking area for cans for pickup within one hundred and fifty (150) feet of each unit . When individual cans are proposed, trash collection plan shall depict stacking area sized to accommodate the number of cans required with a minimum requirement of a 3' by 3' space for each can. The stacking area may be accommodated within a planting strip, or adjacent to a sidewalk. When adjacent to a sidewalk, stacking areas may encroach into sidewalks provided that a minimum width of 4' is maintained along the sidewalk for travel.
- When common trash enclosures are provided, trash collection plan shall depict all common trash enclosure locations. Trash enclosures shall comply with Chapter 30.90 of the Elk Grove Municipal Code (Space Allocation and Enclosure Design Guidelines for Trash and Recycling).



*Mechanical equipment shall be screened from public view*

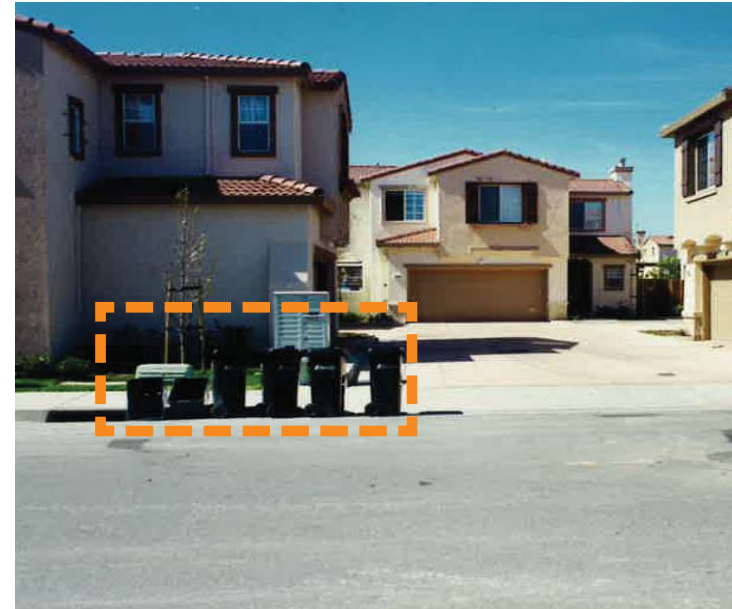

*Stacking area located within one hundred and fifty (150) feet of the units for trash pickup*



## 3.2 ARCHITECTURE FOR MASTER HOME PLANS

The previous section of the Design Guidelines for Single-family Residential Development relates to land planning for subdivision maps. This section of the document builds upon those provisions but focuses on the master home plans. The single-family residential Design Guidelines provide recommendations to promote high quality neighborhoods which result in a more attractive, pedestrian friendly and sustainable environment. Guidelines herein are intended to supplement the single-family development standards in the Zoning Code.

Design Review is required for master home plans developed for each subdivision or each individual neighborhoods in the City. Design Review approval for master home plans is required prior to issuance of building permits for model homes and all subsequent homes within the identified development.

The City encourages variety along the streetscapes in new developments and quality of architecture for individual homes and has created these architectural Guidelines for master home plans, which achieve the following:

- **Pedestrian friendly streetscapes where homes are oriented to the street, paseos or walkways and to open space areas.**
- **Home designs that incorporate a diversity of architectural styles.**
- **Variety in mass and scale of homes that is visually appealing from the street.**
- **Landscape that complements the buildings and provides an eventual tree canopy along the street and is adapted to the local climate.**

The City recognizes the unique design characteristics of high-density, small lot residential developments as a means of providing more affordable housing in a traditional suburban setting. The Design Guidelines incorporate special architectural guidelines to ensure design flexibility for small lot development.



*Pedestrian friendly streetscape with homes oriented toward the street*



*A variety of mass and scale between different homes*



*Varying architectural style along the streetscape*

## A. STREETScape VARIETY THROUGH RESIDENTIAL DESIGN

In order to achieve streetscape variety within a subdivision and to create a pedestrian friendly streetscape, variations in plan types, elevations, design features and incorporation of certain design techniques are required.

### A.I. FLOOR PLAN TYPES

To achieve variation in subdivisions, each home plan within the master home plans series should have a distinct footprint in terms of the placement and relationship of the garage, interior living space, and any designated outdoor living space or entry feature. The intent is to create structural and spatial variety along residential streetscapes by creating distinct

configurations of garages and livable space between home plans along the street. To create enough variety of plans and elevations within each subdivision a minimum number of floor plans and elevations is required based on the number of units within the subdivision as listed in Table 3.1. The requirements below include a standard and an alternative either of which may be used.

TABLE 3.1: PLANS AND ELEVATIONS REQUIRED

# OF UNITS	MINIMUM # OF PLANS AND ELEVATIONS (STANDARD)	MINIMUM # OF PLANS AND ELEVATIONS (ALTERNATE)
<b>UP TO 50 UNITS</b>	<ul style="list-style-type: none"> <li>» Min. of two (2) floor plans</li> <li>» Min. of three (3) elevations for each plan</li> </ul>	<ul style="list-style-type: none"> <li>» Min. of three (3) floor plans</li> <li>» Min. of two (2) elevations for each plan</li> </ul>
<b>51-100 UNITS</b>	<ul style="list-style-type: none"> <li>» Min. of three (3) floor plans</li> <li>» Min. of three (3) elevations for each plan</li> </ul>	<ul style="list-style-type: none"> <li>» Min. of four (4) floor plans</li> <li>» Min. of two (2) elevations for each plan</li> </ul>
<b>101-200 UNITS</b>	<ul style="list-style-type: none"> <li>» Min. of four (4) floor plans</li> <li>» Min. of three (3) elevations for each plan</li> </ul>	<ul style="list-style-type: none"> <li>» Min. of six (6) floor plans</li> <li>» Min. of two (2) elevations for each plan</li> </ul>
<b>MORE THAN 200 UNITS</b>	<ul style="list-style-type: none"> <li>» Min. of five (5) floor plans</li> <li>» Min. of four (4) elevations for each plan</li> </ul>	<ul style="list-style-type: none"> <li>» Min. of seven (7) floor plans</li> <li>» Min. of two (2) elevations for each plan</li> </ul>



Mix of one and two-story plans required except in RD-8 RD-10, and RD-15 zoning designations



To create changes in building heights and varied street interface the following also shall apply to single family developments, other than those in RD-8, RD-10 and RD-15 zoning designations or to subdivisions of twenty units or less:

- A minimum of one of the home plans in each master home plan series shall be a single-story.
- A minimum of one third of the home plans shall have a designated outdoor living area (e.g., porch, courtyard) front the street or a paseo, that is at least five feet deep and eight feet wide to accommodate seating and neighborhood gathering.



Example of incorporating a minimum 5x8 foot porch on the front entry



Incorporate a variety of elevations of the same floor plan: example of a Spanish elevation



Incorporate a variety of elevations of the same floor plan: example of a Craftsman elevation



Incorporate a variety of elevations of the same floor plan: example of a European Cottage elevation

## 3.0 Single Family Residential Development

### A.II. VARYING DESIGN ELEMENTS CREATE INTEREST AND VARIETY

The design of structures shall be varied along a street to create variety and interest. Variation may be achieved by a meeting a minimum of one of the design techniques listed below:

- Incorporate varied architecturally appropriate roof lines into each home within the master home plan series. Variations in roof forms can be achieved by using a minimum of one of the design techniques listed below:
  - Mix of single and multi-story roof elements.
  - Mix of two or more roof styles (gable, hip, shed, flat etc).
  - Change in ridge line directions or change in roof pitch.
- To ensure variety in home frontages along the street, no two identical floor plans and elevations shall be placed on lots within a group of five adjacent lots. For purposes of this section, “adjacent lots” shall mean those lots on either side of a subject lot and those three lots directly across the street from the subject lot (referred to as a “six pack”). Deviations from this requirement may be allowed for smaller subdivision (<50 lots) and townhome style developments. Two of the same floor plans with different elevations may be placed adjacent to one another if one of the floor plan is reversed.
- Use of horizontal staggering of homes by varying location of homes from the front setback on individual lots along the street.

### A.III. BULK AND MASS

- Placement of building sites should consider the existing context of the surrounding area. Proposed homes should respect the privacy and solar access of any existing home through appropriate siting of structures.
- The City encourages the design of individual homes to minimize bulk and mass, to create a pedestrian scaled streetscape. A minimum of one of the design techniques listed below shall be utilized to reduce bulk and mass:
  - Stepping back of the second story along the front elevation. A minimum of thirty (30) percent of the two story portion of the front elevation shall be setback a minimum of five (5) feet behind the front facade.
  - Incorporation of single story roofs or single story elements such as porches along the



*Incorporate a variation in roof forms and elements*



*NOT RECOMMENDED: No two identical floor plans adjacent one another*



street frontage to lower the building mass. Single story element shall be a minimum of twenty (20) percent of the width of the front elevation.

- Use of decks and balconies on the second story to reduce the two story vertical mass along the street frontage. The decks and balconies shall extend a minimum of two (2) feet beyond the lower story and constitute a minimum of twenty (20) percent of the width of the front facade.
- Keep the second floor exterior wall heights lower than twelve (12) feet. Wall height measured from second floor to top of plate where the roof meets the wall.
- Locate chimneys on an internal wall or centered on a gable end.

**STREET FACING ORIENTATION**



*Example of a single story porch and roof elements along the street*

**DE-EMPHASIZE THE GARAGE**

**INCORPORATE PORCHES**



*De-emphasize the appearance of the garage and encourage porches*



*Example of incorporating a second floor balcony to reduce mass*



*Example of second story being setback from the front facade*



*Example of chimney located on an internal wall away from street view*

## B. COLOR AND MATERIALS

Colors and materials create variety and diversity of the streetscape. A variety of materials and colors of the buildings when combined with the variation in floor plans and elevations styles would help in the creation of aesthetically pleasing diverse streetscape.

- Materials and finishes shall be consistent with the architectural style of the proposed home.
- Each architectural style within a master home plan series shall include at least three color schemes. The intent is to have distinct color palettes for elevations types with similar architectural styles among floor plans in the master home plan series.
- The City encourages the use of comparable levels of detailing/finish on all elevations of the structure (e.g., recessed, pop out, or trim features). However, emphasis shall be placed

on designing superior architectural detailing on front elevations and other elevations visible from public streets and open space.

- All architectural treatments on the front elevation (e.g., fascia treatments such as stone veneer) shall be extended or wrapped a minimum distance four (4) feet along the side yard elevations or to the side yard fence, or to the point of the wall where there is change in plane of minimum one foot. Such treatment shall accommodate and incorporate the location of any service panels flush against the building façade.
- Window treatments, such as trims, recesses, awnings, and shutters shall be required on all elevations, consistent with the architectural style of the home. Shutters shall be sized consistent with the size of the corresponding window.
- Drain spouts shall be painted to match the corresponding wall colors.



**MATERIALS SHALL WRAP THE INSIDE CORNER A MIN. 4 FEET OR TO NEAREST FENCE**



*Incorporate a variety of colors and materials throughout the project*



## C. ARCHITECTURAL STYLES

The City of Elk Grove possesses a rich tradition of residential architecture. The older residential neighborhoods contain re-stored examples of Craftsman, California Bungalow, Queen Anne Cottage, Ranch and other architectural styles from the turn of the century. Good modern architecture is also evident in the City. Although no particular “style” is required for new residential construction, the proposed houses should illustrate quality of craftsmanship and the thoughtful integration of form, massing, and materials. The following guidelines apply to all homes regardless of the architectural style:

- All homes within a master plan series shall be designed with an authentic architectural style. That style shall be reflected in building form, decorative features, materials and colors. Diversity of architecture is encouraged throughout the community and within neighborhoods. However, only one architectural style shall be represented on an individual elevation of each home plan in a master home plan series and that style shall be authentically represented.
- A subdivision may be themed (one prominent architectural) style or be a combination of architectural styles that give the impression of a more organic development.

- Windows shall be appropriate to the building’s architectural style. Window grids, if appropriate to the architectural style and used on the front elevation, should be used on all elevations.
- Windows shall be articulated through the use of details such as recessing, sills, trim, kickers, shutters or awnings that are authentic to the architectural style of the building. Shutters shall be sized consistent with the size of the corresponding window.
- Gutters, downspouts, and flashing shall be painted to match the surface to which attached.
- The City requires the use of four sided architecture – where the level of articulation of wall planes, materials, detailing and finishes are continued from the front to all sides of the building. However, the City does recognize that certain elevations are less visible from public streets or walkways, so additional enhancements might not be visible. In such cases emphasis should be placed on designing superior architectural detailing on front elevations and other elevations visible from public streets and open space.

The following pages illustrate some examples of traditional residential architectural styles that are common in Elk Grove. The following residential styles

are not intended to be the only styles allowed, but are intended to represent the defining characteristics of individual styles that are prevalent in Elk Grove. When other styles or other variations to the outlined styles are proposed, the applicant is encouraged to illustrate how the proposed architecture of the project is compatible/ reflective to the style proposed. Each of the illustrated styles have a brief history and description of the style for reference and a table with objective required elements that need to be incorporated in the design to satisfy the style requirements.

Materials mentioned are for visual quality. Materials may be substituted by other materials as long as they maintain the visual character of the intended material (e.g. a stone veneer instead of stone masonry or a fiberglass column with wood like appearance in place for wood columns).

### 3.0 Single Family Residential Development



#### EUROPEAN COTTAGE

**HISTORY:** The European Cottage is a style that evolved out of Medieval Tudor and Norman architecture. The combination of these two architectural influences eventually translated into the popular English and French “Cottage” style homes that received further acceptance with the addition of stone and brick veneer details developed in the 1920s.



**DESCRIPTION:**

This evolving architectural style is characterized by its steep roofs, that are usually side-gabled, and facades that are dominated by cross gables. The primary material is stucco with heavy use of stone and brick at bases, as are rounded doorways, multi-paned casement windows, large and elaborate chimney feature. Some of the most recognizable features for this style are the accent details in gable ends, sculptured swooping walls at the front elevation and tower or alcove element at the entry.



**EUROPEAN COTTAGE**

ELEMENTS	ARCHITECTURAL STYLE DEFINING FEATURES
<b>FORM ELEMENT: MINIMUM TWO ELEMENTS REQUIRED</b>	
<b>FORM</b>	<ul style="list-style-type: none"> <li>» Steep pitched roof (Min 6:12) Min. 40% of the front elevation)</li> <li>» Side-gabled along front elevation (40% of the front elevation)</li> <li>» Gable roof overhang with 9"-24" eave</li> <li>» Roof material: Dimensional asphalt shingles or smooth flat concrete tiles</li> </ul>
<b>DESIGN ELEMENT: MINIMUM THREE ELEMENTS REQUIRED</b>	
<b>DESIGN ELEMENTS</b>	<ul style="list-style-type: none"> <li>» Walls (min 60%) of the surface: Stucco – sand, light lace, or medium dash finish</li> <li>» Stone or Brick around the main entryway</li> <li>» Casements windows or double hung sash windows</li> <li>» Louver and panel shutters on windows</li> <li>» Arched doorways</li> <li>» Boxed eaves</li> </ul>





### 3.0 Single Family Residential Development



#### CRAFTSMAN

**HISTORY:** The Craftsman style was inspired by the English Arts and Crafts movement of the late 19th Century, and is considered native to the California architectural tradition with notable early contribution by architects such as Greene and Greene and Bernard Maybeck.

**DESCRIPTION:**

The physical character is dominated by its low-pitched, gabled roof with wide, unenclosed eave overhang. In addition, the style features exposed roof rafters and decorative beams or braces commonly added under gables. Large porches with distinctive supporting columns that extend across the entire front of the house along with extensive use of natural materials (wood and stones) are all defining features of the Craftsman style.



**CRAFTSMAN**

ELEMENTS	ARCHITECTURAL STYLE DEFINING FEATURES
<b>FORM ELEMENT: MINIMUM TWO ELEMENTS REQUIRED</b>	
<b>FORM</b>	<ul style="list-style-type: none"> <li>» Low pitched roof slopes (3:12 - 5:12) . Min. 40% of the front elevation)</li> <li>» Gabled along front elevation (40% of the front elevation)</li> <li>» Projecting eaves with exposed rafter tails and decorative beams or braces under the gables (12"-30" deep)</li> <li>» Roof material: Flat concrete tile or dimensional composition shingles</li> </ul>
<b>DESIGN ELEMENT: MINIMUM THREE ELEMENTS REQUIRED</b>	
<b>DESIGN ELEMENTS</b>	<ul style="list-style-type: none"> <li>» Front porch, mi 5' deep with columns,</li> <li>» Square or tapered columns on the porch</li> <li>» Low square porch pedestals supporting the columns</li> <li>» Use of stucco and siding on the front elevation</li> <li>» Stone or Brick accent material on front elevation</li> <li>» Multi-pane, double-hung casement windows</li> <li>» Dormers with gable roof on the front elevation</li> <li>» Partially paned doors.</li> </ul>





## CONTEMPORARY HISTORY:

Contemporary styled homes continue to grow in popularity. Contemporary style homes take traditional styles and contemporize the shapes, massing and details, which often appeals to a younger demographic of homeowner. Simple detailing and careful selection of low maintenance materials characterize this style.



**DESCRIPTION:**

Sculptural forms can include smooth surfaces, shifted volumes, and projecting cantilevers. Floor-to-ceiling windows and an array of square openings placed throughout the façade present straightforward geometry. Retractable shutter panels provide ways to both shade interiors from daylight while maintaining a cutting-edge look. A mix of roof styles can include hip, gable, and sloping shed. A mix of stucco and wood, horizontal lines with contrasting vertical towers or elements and distinct design elements such as sunshades add to the new geometry of the Contemporary home.



**CONTEMPORARY**

ELEMENTS	ARCHITECTURAL STYLE DEFINING FEATURES
<b>FORM ELEMENT: MINIMUM TWO ELEMENTS REQUIRED</b>	
<b>FORM</b>	<ul style="list-style-type: none"> <li>» A mix of varying roofed pitches and styles: low (3:12 - 5:12) and steep-pitched roof slopes (8:12 - 10:12) with or without flat roofs</li> <li>» Shed roofs on the front elevation</li> <li>» Wide eaves with enclosed rafter tails, decorative beams/braces under gables (12"-30")</li> <li>» Roof material: Flat concrete tile, composition shingles, or standing seam metal roofs (for pitched roofs)</li> </ul>
<b>DESIGN ELEMENT: MINIMUM THREE ELEMENTS REQUIRED</b>	
<b>DESIGN ELEMENTS</b>	<ul style="list-style-type: none"> <li>» Double-hung casement windows on the front elevation</li> <li>» Storefront window on the front elevation on the ground floor</li> <li>» Modern /Contemporary garage door</li> <li>» Use of three of more materials on the front elevation</li> <li>» Use of three of more colors on the front elevation</li> <li>» Metal railings on balconies</li> <li>» Windows on twow adjoining faces on the front/side elevation to form corner glazing</li> <li>» Porch with no railings (min. 5' deep)</li> </ul>





## MODERN FARMHOUSE HISTORY:

The Modern Farmhouse style is a contemporary interpretation of the traditional farmhouse that incorporates classic farmhouse elements such as gable end roofs, strong vertical lines, and a sense of overall symmetry and puts a contemporary spin on them for a more streamlined modern feel. Modern Farmhouse homes are simply framed and rectangular in shape, with the most recognizable characteristic being the gable roof, typically with a 12:12 pitch. The steep pitch emphasizes the height of the house, and sets the tone for strong vertical lines.





**DESCRIPTION:**

Most Modern Farmhouse-styled homes are two-story buildings with symmetrical arrangement of parts, with entrance at the center and typically a strong vertical element capped with a gable roof. A short set of wide steps leads from the sidewalk to the porch at the front entrance. The two main exterior siding materials commonly found on Modern Farmhouse styles are lap, and board and batten. Shutters commonly found on the traditional farmhouse are typically replaced with horizontal working barn door style shutters.



**MODERN FARMHOUSE**

ELEMENTS	ARCHITECTURAL STYLE DEFINING FEATURES
<b>FORM ELEMENT: MINIMUM TWO ELEMENTS REQUIRED</b>	
<b>FORM</b>	<ul style="list-style-type: none"> <li>» 6:12 to 12:12 roof pitch</li> <li>» Front-to-back main gable roof (min. 40% of the front elevation)</li> <li>» 12" minimum overhangs</li> <li>» Roof material: Smooth, flat concrete tiles, composition singles or standing seam metal</li> </ul>
<b>DESIGN ELEMENT: MINIMUM THREE ELEMENTS REQUIRED</b>	
<b>DESIGN ELEMENTS</b>	<ul style="list-style-type: none"> <li>» Blend of siding, stone and stucco. Stucco to be sand, light lace, or medium dash finish</li> <li>» Panel or barn door style shutters</li> <li>» Porch with wood columns</li> <li>» Double hung windows on the front elevation</li> <li>» Header trims on front windows</li> <li>» Sidelight entry door</li> <li>» Standing seam roofs -main roofing materials or as an accent over windows or porches</li> </ul>



### 3.0 Single Family Residential Development



#### MONTEREY REVIVAL HISTORY:

The Monterey Revival style is said to be derived from Thomas O. Larkin, who has pioneered the architectural style with the first Monterey home, the Larkin House, in Monterey, California in the 19th century. Monterey Revival is a mix of local adobe construction with New England Colonial architecture. The two main notable features of the Monterey Revival include the two-story construction that stood out to the all single-story Spanish Colonial homes during that time, and the exterior balcony. The typical form is a rectangular plan with one end projecting out beyond the second floor balcony, which is often supported by wood brackets and/or posts.



**DESCRIPTION:**

Most Monterey Revival homes are recognized for their signature two-story construction and an exterior second-story only balcony. Some of the notable features include covered front porches, simple hip and/or gable roof forms, symmetrical windows, and adobe walls. Additional features may include a low pitched gable roof with tiles, double-hung windows, plaster or adobe walls, and exposed beam detailing.



**MONTEREY REVIVAL**

ELEMENTS	ARCHITECTURAL STYLE DEFINING FEATURES
<b>FORM ELEMENT: MINIMUM TWO ELEMENTS REQUIRED</b>	
<b>FORM</b>	<ul style="list-style-type: none"> <li>» 4:12 to 5:12 roof pitch</li> <li>» Front-to-back main gable roof on the front elevation (min 20% of the front elevation)</li> <li>» 12" - 24" eave overhangs</li> <li>» Roof material: s-shape concrete or flat concrete tiles or composition singles</li> <li>» Second story balcony on the front elevation ( Min. 25% of the front width of the house)</li> </ul>
<b>DESIGN ELEMENT: MINIMUM THREE ELEMENTS REQUIRED</b>	
<b>DESIGN ELEMENTS</b>	<ul style="list-style-type: none"> <li>» Blend of stone and stucco. Stucco to be sand, light lace, or medium dash finish</li> <li>» Double-hung windows on front elevation</li> <li>» Wood or wood-like balcony with square posts and railing on the front elevation</li> <li>» Full-length windows or glazed doors opening to the balcony</li> <li>» Shutters on windows on the front elevation</li> <li>» Main entry located under second story balcony</li> <li>» Exposed rafter tails and decorative support beams</li> </ul>



### 3.0 Single Family Residential Development



#### SPANISH REVIVAL

##### HISTORY:

The Spanish Revival architectural style became popular in the Western and Southwestern United States in 20th century. The style is reminiscent of the architectural traditions of the Spanish Empire in North America. Spanish Revival is never a single, consistent architectural style, but rather an aesthetic which mixes and matches elements of various styles to produce a desired visual impact. The features commonly used to create this impact includes low-pitched roofs with little or no eave overhang often covered with red tiles, stucco exteriors with rounded arches over windows and doors, and a facade often asymmetrical.

**DESCRIPTION:**

Most Spanish Revival homes are most recognized for their red tiled roofs, either Mission tiles (half-cylinder shape) or Spanish tiles (S-curve shape). Dramatically carved doors are common emphasized by spiral columns, pilasters, carved stonework or patterned tiles. Typically there is at least one large focal window often arched or similar parabolic shape. Windows typically have decorative grilles made of wood or iron often with intricate detailing. Stucco walls could be smooth or have various rough or tooled finishes.



**SPANISH REVIVAL**

ELEMENTS	ARCHITECTURAL STYLE DEFINING FEATURES
<b>FORM ELEMENT: MINIMUM TWO ELEMENTS REQUIRED</b>	
<b>FORM</b>	<ul style="list-style-type: none"> <li>» 4:12 to 5:12 roof pitch</li> <li>» Hip or gable roof intersecting a gable</li> <li>» 0"-12" overhang with tight rake on gable ends</li> <li>» Roof material: S-shape concrete or half-cylinder shale concrete tiles</li> </ul>
<b>DESIGN ELEMENT: MINIMUM THREE ELEMENTS REQUIRED</b>	
<b>DESIGN ELEMENTS</b>	<ul style="list-style-type: none"> <li>» Stucco light sand finish</li> <li>» Wrought iron or wood like detailing on balconies on the front elevation</li> <li>» Arch or parabolic archway around entry door</li> <li>» Tiled accent around main door</li> <li>» Recessed window</li> <li>» Double-hung or casement windows</li> </ul>







## TUSCAN

**HISTORY:** The Tuscan style is reminiscent of the traditional architecture of Tuscany. The homes are known for their simple, clean lines with natural elements to maintain a rustic, yet sophisticated style. They are known for their s-curve tile roofs with natural hues to match the stucco exteriors and accents often wrapped in a warm range of yellows, browns, reds and greens. Typically the low pitched gable roof contains a gable end accent to highlight the entry of the home while incorporating a shed roof to create interest and variety.





**DESCRIPTION:**

Most Tuscan homes are notably recognized for the natural elements they possess. They typically have a stucco light sand finish with an element wrapped in stone veneer. The symmetrically arranged windows along the front facade are typically recessed to mimic the appearance of thick walls, often flanked with louvered or panel shutters. Wrought iron accents are a common feature used in railings, pot shelves, and window awnings. Typically the front doors are simple yet made to be a highlighted feature.



**TUSCAN**

ELEMENTS	ARCHITECTURAL STYLE DEFINING FEATURES
<b>FORM ELEMENT: MINIMUM TWO ELEMENTS REQUIRED</b>	
<b>FORM</b>	<ul style="list-style-type: none"> <li>» 4:12 to 5:12 roof pitch</li> <li>» Hip or gable roof intersecting a gable</li> <li>» 0"-12" overhang with tight rake on gable ends</li> <li>» Roof material: S-shape concrete</li> </ul>
<b>DESIGN ELEMENT: MINIMUM THREE ELEMENTS REQUIRED</b>	
<b>DESIGN ELEMENTS</b>	<ul style="list-style-type: none"> <li>» Stucco light sand finish with stone veneer accents on front elevation</li> <li>» Double-hung or casement windows</li> <li>» Exposed rafter extensions and brackets</li> <li>» Tiled accent around main door</li> <li>» Recessed accent window</li> <li>» Wrought iron detailing on the front elevation</li> <li>» Louver and panel shutters</li> </ul>

### 3.0 Single Family Residential Development



#### PRAIRIE

**HISTORY:** The Prairie style is derived from a combination of the Arts and Crafts movement with an emphasis on nature, craftsmanship and simplicity. The homes are known for the emphasis on the horizontal rather than the vertical. The homes tend to span out over their lots and feature flat, low or shallow hipped roof lines, rows of windows, overhanging or cantilevered eaves and bands of stone, wood, or brick across the surface. Often downspouts are either eliminated or carefully placed to minimize their appearance. The Prairie style is referred to, as Frank Lloyd Wright said, “married to the ground”. They resemble the long and low landscape often found in the Midwest.



**DESCRIPTION:**

Most Prairie homes are notable recognized for their focus on horizontal elements which provide an appearance of being low to the ground. They are generally two-story structures with single-story wings. The roof forms are generally flat or low sloping, often hipped and include large overhangs and cantilevers that were long, horizontal and flat. The exterior materials tend to include the use of stone, wood, or brick. Windows are typically large and sometimes take up entire walls and often include intricate detailing to seem more like a piece of art.



**PRAIRIE**

ELEMENTS	ARCHITECTURAL STYLE DEFINING FEATURES
<b>FORM ELEMENT: MINIMUM TWO ELEMENTS REQUIRED</b>	
<b>FORM</b>	<ul style="list-style-type: none"> <li>» Max. 4:12 roof pitch on the primary roof</li> <li>» Hip or flats roofs</li> <li>» Wide overhangs (36" min) with boxed eaves</li> <li>» Roof material: Smooth, flat concrete tiles or composition singles</li> </ul>
<b>DESIGN ELEMENT: MINIMUM THREE ELEMENTS REQUIRED</b>	
<b>DESIGN ELEMENTS</b>	<ul style="list-style-type: none"> <li>» Stucco light sand finish or horizontal board and batten</li> <li>» Brick/Stone veneer accents on the front elevation</li> <li>» Casement windows</li> <li>» Windows surrounded by 4"-6" moldings</li> <li>» Exterior lighting referred to as "Prairie" or "Mission" style</li> <li>» Muttons incorporated into windows</li> <li>» Mitered or corner clip corners</li> <li>» Frieze boards located between window and window head</li> </ul>



## D. GARAGE PLACEMENT

It is anticipated that the master home plans will have a variety of garage placements to ensure that garages in single-family residential neighborhoods not dominate the streetscape. Garages may be located in various locations depending on the housing type proposed. The sections below address the requirements based on the garage access.

### D.I FRONT LOADED GARAGES

To ensure that the garages will be subordinate to the main living area/designated outdoor living space and not dominate the streetscape the following is required for all front loaded plans.

- **RD-1 to RD-6 districts:** All home plans are required that the garage door be setback at a minimum the same distance as the livable portion of the house or the porch. When computing master home plan requirements, fractional numbers of one-half (0.5) or more shall be rounded off to the nearest whole number. This restriction only applies to street facing garage doors and is not intended to limit garage doors located perpendicular to the street or along side streets.
- **RD-7 and above:** All home plans shall have the garage door be setback a minimum the same distance as the livable portion of the house or the porch. At least two in every three home plans shall have the garage located a minimum

of five feet behind the livable portion of the house or a porch or a patio.

- Garage door width facing the street shall not exceed the percentages stated below in Table 3.3. The maximum percentages are derived by dividing the width of the garage door by the width of the house. Recognizing the design constraints on small lots the percentages vary based on the zoning categories. These restrictions do not apply to homes in a cluster development where the garages accessed from a shared driveway.

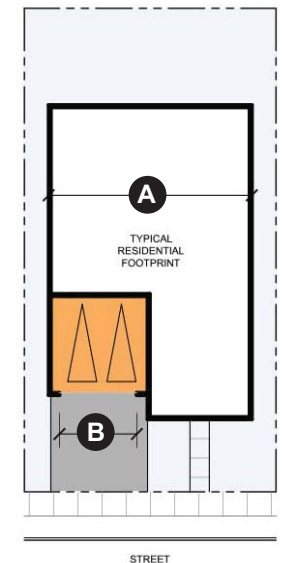

TABLE 3.2: GARAGE FORWARD PLANS AND FRONTAGES ALLOWED

FRONT LOADED GARAGE REQUIREMENT	RD-1 TO RD-5	RD-6 TO RD-7	RD-8 AND ABOVE
<b>GARAGE FORWARD PLANS</b>	» None	» None	» None
<b>GARAGE FRONTAGE ALONG STREET (B/A %)</b>	» Max. 45%	» Max. 55%	» Max. 60%

TABLE 3.3: GARAGE VARIETY REQUIRED

FRONT LOADED GARAGE REQUIREMENT	UP TO 50 UNITS	51-100 UNITS	101 UNITS AND ABOVE
<b># OF GARAGE PLACEMENT DESIGN SOLUTIONS (RD-1 TO RD-6)</b>	» Min. 2	» Min. 3	» Min. 4
<b># OF GARAGE PLACEMENT DESIGN SOLUTIONS (RD-7 AND ABOVE)</b>	» Min. 1	» Min. 2	» Min. 3



**A** WIDTH OF THE HOUSE  
**B** GARAGE

- In addition to create variety the home plans shall incorporate one or more of the designs listed based on the requirement in Table 3.3. The City recommends a combination of the garage placement design solutions below, rather than one single solution for all home plans.
  - Setback the garage the same distance as the living area of the home or the outdoor living area of the home, such as porches, stoops, deck or courtyard.
  - Recess the garage behind the living area of the home or behind the outdoor living area of the home, such as porches, stoops, deck or courtyard a minimum of five (5) feet.
  - Place the garage perpendicular to the street (side-on garage). The façade of the garage facing the street shall include windows which are similar in detailing and style as the windows on the home.
  - Utilize single car garage doors to minimize the garage door width.
  - Place the garage at the rear of the lot, attached or detached from the main dwelling.
  - Cantilever the second story (or project a portion thereof) out over the garage. The cantilever could be part of the living area of the second floor or could be deck or a

balcony that projects over the garage. The cantilever shall be a minimum fifty (50) percent of the width of the garage door and shall project a minimum of one and half (1.5) feet beyond the garage door.

- Recess the garage by extending the living portions of the upper story of the house over the garage so that the garage is recessed by a minimum of three (3) feet.
- Develop a tandem garage so that the appearance from the street is that of a single-car garage.
- Incorporate a trellis over the garage opening or the garage doors. The trellis shall extend a minimum of five (5) feet beyond the garage door.
- Use garage doors that are articulated with windows.
- Incorporate permeable pavers or greenery within the driveway. The pavers or the greenery shall constitute a minimum of



*Example of the garage located in the rear of the lot*



*Example of cantilevering the second floor over the garage*



*Example of the garage set back behind the porch*



*Example of a recessed garage door created the by extending the upper story*

### 3.0 Single Family Residential Development

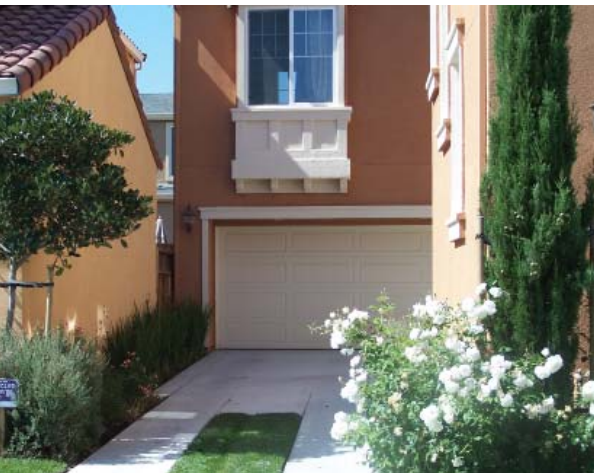
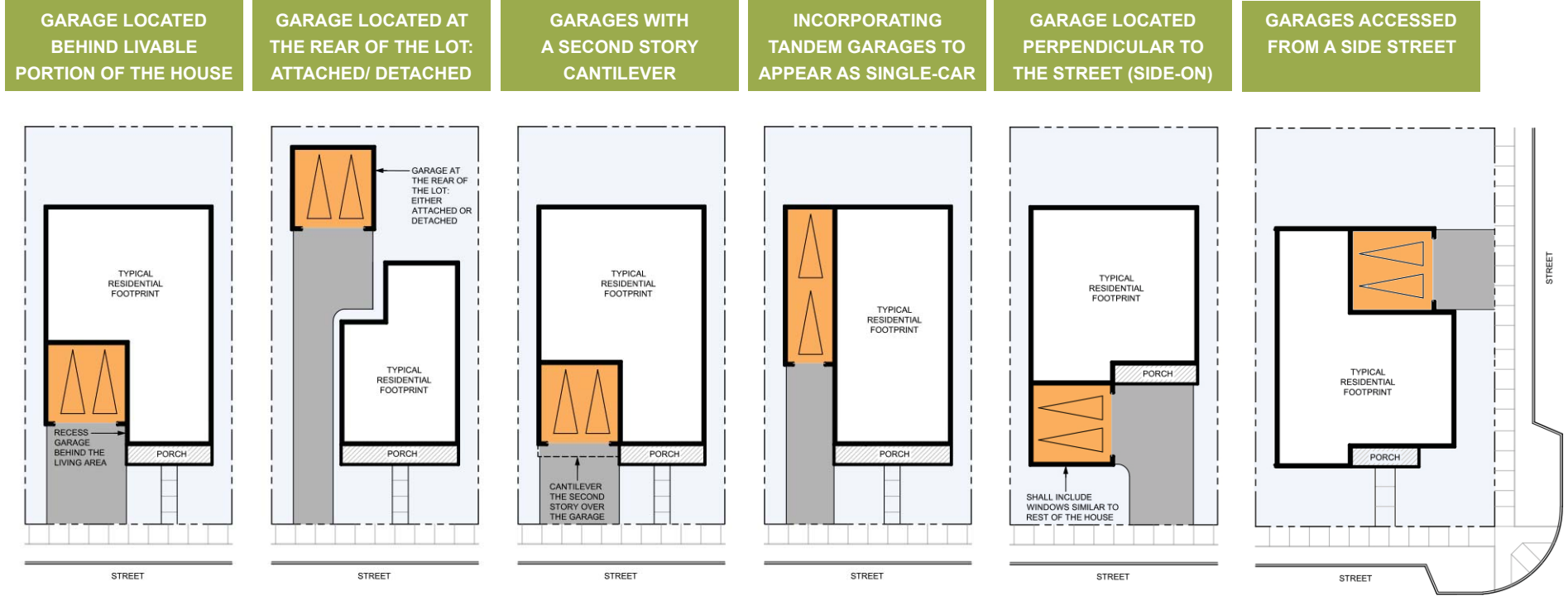

Example of integrating greenery on the driveway



Example of balcony cantilevering over the garage



Example of a single car garage door use



twenty percent (20%) of the driveway area.

- Other garage placements/designs that are not listed above but serve the functional equivalent to minimize the visual dominance of the garage from the street are allowed.
- When located on corner lots, du-plexes and half-plexes shall be designed with garage doors facing opposite streets. When located on interior lots, duplexes and half-plexes shall be designed so that the garages for the two units are not adjacent to each other. This restriction does not apply if the garages are accessed from an alley.

## D.II ADDITIONAL GUIDELINES FOR THREE- OR MORE- CAR GARAGE DESIGN

In addition to the previous garage placement provisions, the City desires to minimize the appearance of three or more car garages facing the street. To that end, at least one of the design options listed below shall be utilized for each three or more car floor plan within the master home plan series.

- Garage doors facing the street shall be maximum two car garage door wide.
- Design three-car garages with at least one individual single car garage door.

DUPLEX LOCATED ON INTERIOR LOTS

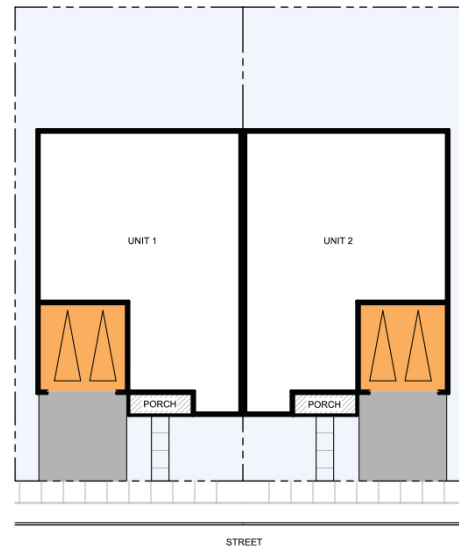

DUPLEX LOCATED ON CORNER LOTS

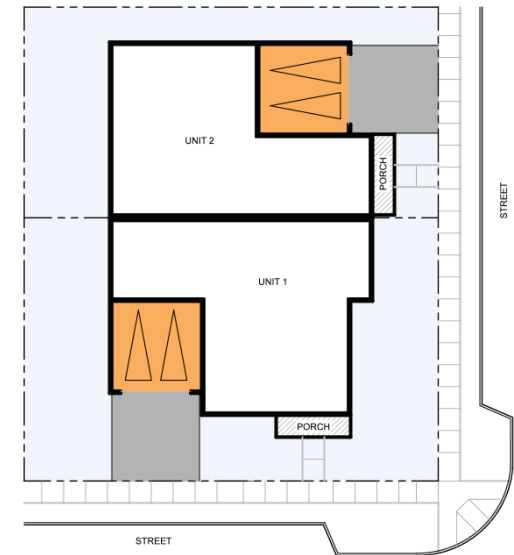

- All garages shall be designed with articulated garage doors (e.g., windows, paneling, or other high quality detailing).
- Locate the front facing garage behind the living portion of the house or the outdoor living spaces such as porches.
- Accommodate the parking spaces in tandem parking spaces so that a maximum two-car garage faces the street;
- Design a single garage door that is offset or separated a minimum of two (2) from the face of the two-car garage. Additionally, garage doors

in shall be recessed a minimum of one foot from the garage door frame;

- Shift the orientation of the garage so that one or more of the garage doors do not face the street (e.g., side-on garage that is perpendicular to the street). The following regulations apply to side-on garages.
  - The façade of the garage facing the street shall include windows which are similar in detailing and style as the windows on the home.
  - When a side-on garage is developed

### 3.0 Single Family Residential Development

in conjunction with a garage facing the street, main entry to the home shall be visible from the street. Appropriate to the architectural style the entry should be articulated with a clear direct path from the street to the entry. Enhancements to the entry to make it visible are encouraged and depending on the architectural style may include a trellis, arbor, gate, enhanced architectural detailing or accents around the door, low walls, accent landscape, or enhanced pavement.

- Other creative design alternatives that serve the functional equivalent of minimizing the appearance of three garage doors facing the street.

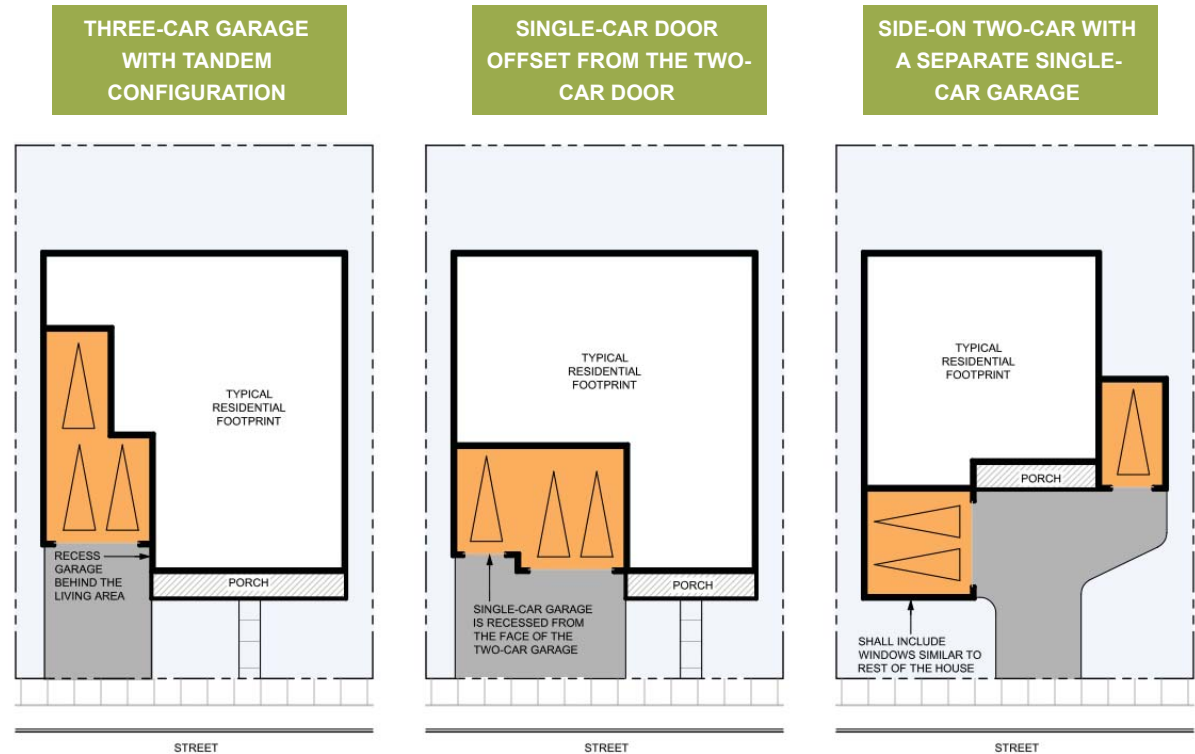

Example of a side-on two-car with a separate single-car garage



Example of recessing the single-car door behind the two-car door



Example of a three-car tandem that appears to be a two-car garage

### D.III ALLEY LOADED GARAGES

Alley loaded garages provide an aesthetically pleasing sound and an urban design alternative to garage dominated street facades. By placing the garage to the rear of the building and providing the access from alleys it facilitates opportunities for pedestrian-friendly, context-responsive street frontages along with allowing for greater interaction between the building and the street. Alley loaded garages may be attached or detached. The City strongly recommends the use of alley loaded garages in the middle density categories. To promote higher density alley loaded housing buildings may front on to streets or on to paseos/ common greens in lieu of streets. The following guidelines apply to developments with alley loaded garages:

- One in every three home plans are required to cantilever, or step back the upper level along the alley. The cantilever or step back shall be a minimum two (2) feet and a minimum of 40% of the width of the garage door. The cantilever may be part of the living area or a deck or a balcony.
- Provide variation along the alley by changing color or style of garage doors. Variation may be achieved by using garage doors of the same style in different colors or by changing the style (e.g. different types of panelled doors, carriage garage doors or garage doors with windows. etc) or both. Number of variations required shall be as per Table 3.4

**TABLE 3.4: GARAGE VARIETY REQUIRED**

ALLEY LOADED GARAGE REQUIREMENT	UP TO 50 UNITS	51-100 UNITS	101 UNITS AND ABOVE
<b>CANTILEVER / STEP BACK REQUIRED</b>	» Min. 1/3 of home plans	» Min. 1/3 of home plans	» Min. 1/3 of home plans
<b>VARIATION IN COLOR OR STYLE OF GARAGE DOOR</b>	» Min 2	» Min. 3	» Min 4

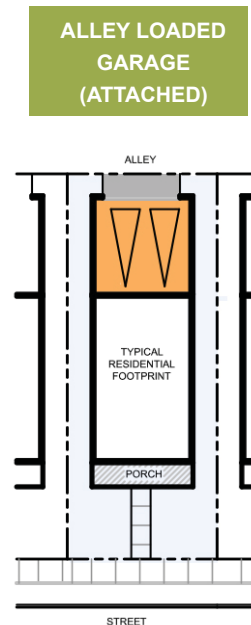
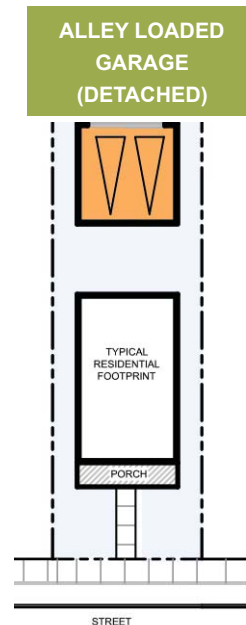

Example of upper level cantilever along the alley



Example of upper level step back along the alley



Example of variation in garage door color



This page is intentionally left blank

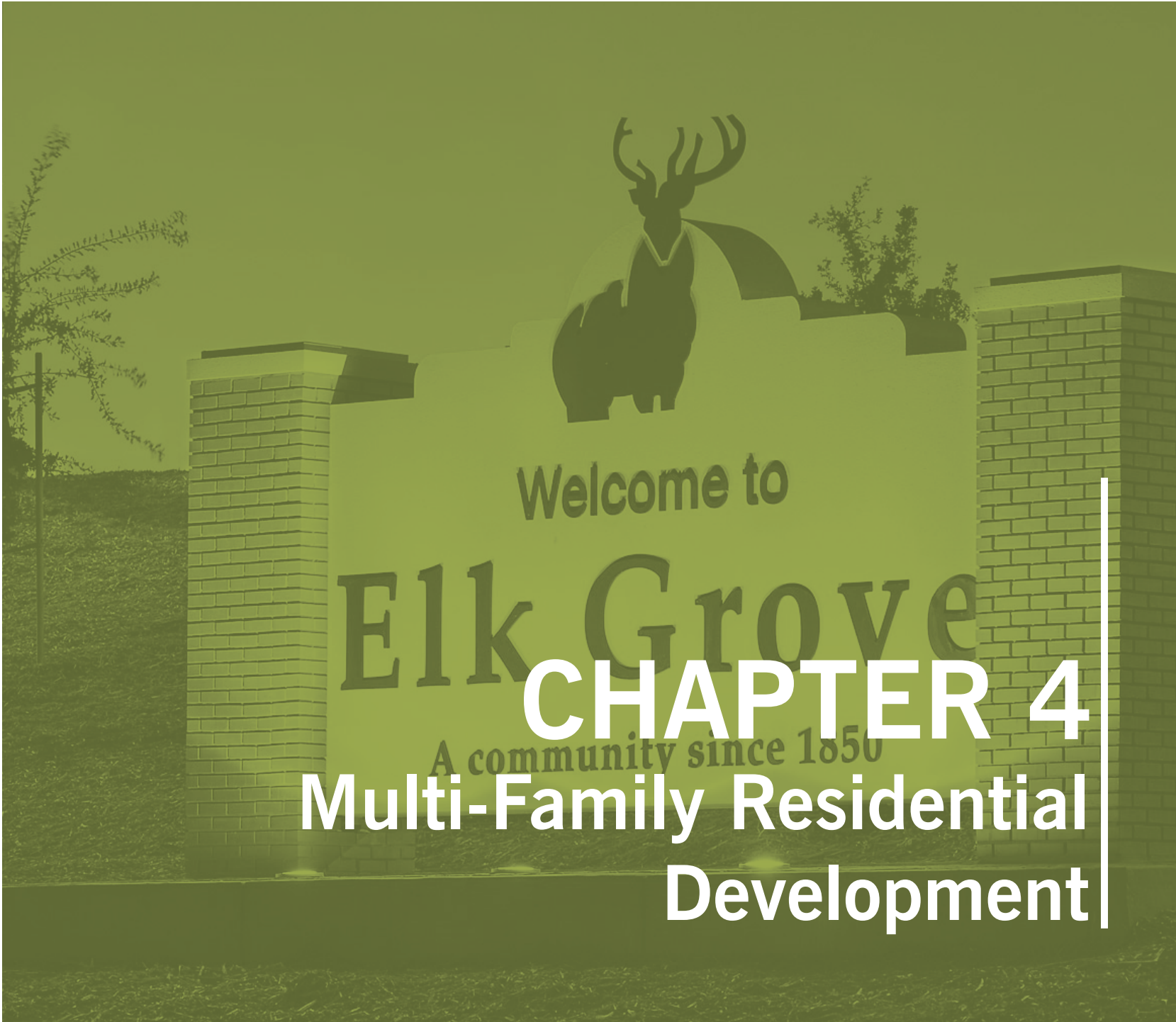

**CHAPTER 4**  
**Multi-Family Residential  
Development**





## 4.0 INTRODUCTION

*This section of the Design Guidelines applies to all multi-family development of three or more attached units. For the purposes of these Guidelines, multi-family development includes, but is not limited to, apartments, townhouses, condominiums, stock cooperatives, and triplexes. For horizontally mixed-use projects the Design Guidelines in this chapter shall apply to the residential portion of the project. Desired characteristics of multi-family projects:*

- *Ensure that site design and building placement address issues of scale, privacy, noise within the development, and the context of surrounding neighborhoods and land uses.*
- *Encourage project designs that create and enhance a sense of community. Projects should provide community features for enhanced appearance, safety, convenience, and social interaction.*
- *Emphasize placemaking design principles in new multi-family projects*
  - by incorporating community spaces for gathering and social interaction.*
- *Encourage quality architecture with visual variety and interest.*
- *Ensure that multi-family projects support a high quality of life with appropriate allocation and use of common and private open space, community amenities, and landscaping.*
- *Incorporate environmentally sustainable features into the project design, utilizing sustainable design techniques in both site planning and building architecture. At the minimum projects shall meet applicable State Energy regulations and the City of Elk Grove's Water Efficiency Landscaping provisions.*
- *Accommodate for multiple modes of transportation within the project. If transit and multimodal circulation routes exist immediately adjacent to the project the project shall provide non-vehicular connection to those facilities.*

## 4.1 SITE DESIGN

*For the purposes of these Guidelines, site planning is the analysis and resulting design of land that takes into consideration site conditions, surrounding uses, and development opportunities to determine the physical, functional, and visual plan for the development of said property. The following Guidelines are supplemental to the Zoning Code and are intended to facilitate good design practices for multi-family development.*

### A. BUILDING PLACEMENT & SITE ORGANIZATION

Building placement and orientation on all multi-family sites shall take into consideration the residential use from a physical and functional perspective, relationship and compatibility with surrounding uses, and the visual impact and experience for residents, visitors, and passersby.

- When buildings are adjacent to a public street, building entrances shall be oriented to face the public street.
- At least two (2) different building types shall be included in projects with more than four (4) buildings. Building types shall be differentiated through variations to building form, building footprints, and/or rooflines, or appearance through the use of varied materials and color.
- Where buildings are adjacent to parks building entrances shall be located and oriented to front on to parks.
- Where buildings are adjacent to parks, decks and balconies of the building when provided shall overlook parks and community gathering elements.
- Encourage the project design to incorporate existing significant natural features of the site where such features exist. Significant natural features include, protected trees/tree clusters, creeks and waterways.
- Designs that mitigate the potential adverse environmental effects of stormwater runoff through minimization of impervious surfaces, use of design features to prevent pollutants from contacting runoff, and integration of stormwater quality treatment filters including infiltration shall be integrated into the site landscaping.



*Example of building entrances fronting on to a parks*



*Example of variation of building types through change in material and color: two identical buildings with different color and materials scheme*



- To address issues of transition between uses when the proposed multi-family is adjacent to existing single-family development, the proposed development shall be subject to the requirement in Table 4.1 and Transition Graphic below.

TABLE 4.1: TRANSITION REQUIREMENT	
# OF STORIES	MULTI-FAMILY BUILDING HEIGHT SETBACK/ STEPBACK
TWO STORIES	» 30 Feet
THREE STORIES	» 40 Feet
FOUR STORIES	» 50 Feet
FIVE STORIES	» 60 Feet
SIX STORIES AND ABOVE	» 70 Feet



Example of an upper story setback

TRANSITION REQUIREMENT FOR MULTI-FAMILY BUILDINGS WHEN ADJACENT TO SINGLE FAMILY ZONED AREAS

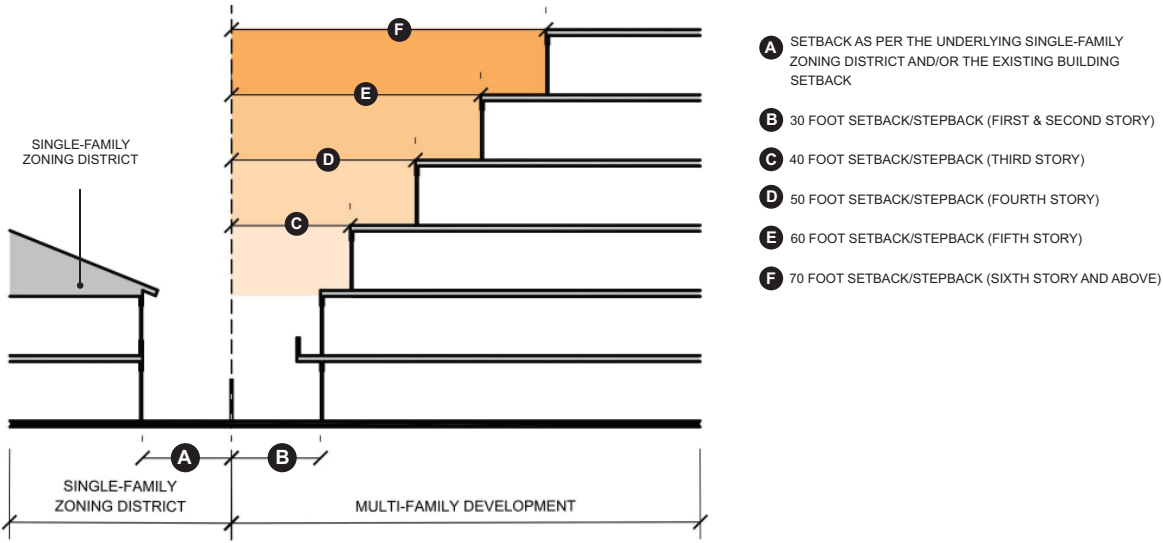

Example of an upper story setback



## B. OPEN SPACE AND AMENITIES

Multi-family sites shall be developed with usable open space areas and amenities for the use and enjoyment of future residents. Open space requirements for multifamily unit shall be as follows:

- A minimum of 100 sf of open space per unit and the areas may be private, common or a combination.
- Private open space shall have a minimum width of five feet and a minimum area of 50 sf. Private open space includes private patios and yards at the ground level and above ground private decks or balconies or private yards for use by individual units.
- Common open space shall have a minimum width of 20 feet with a minimum area of 200 sf. Common open space includes active

and passive recreation areas, other outdoor amenities, and natural open space areas outside of the required setbacks.

- Common open space shall be incorporated into the site plan as a primary design feature and not just remnant pieces of land used as open space.
- The open space should be appropriately sized and located so that it is easily accessible by most residents. Open space should be well defined by streets or buildings.
- Common open space should be centrally located and positioned within the viewshed of the nearest units such that the residents can provide visual informal surveillance.
- Where possible, stormwater treatment areas shall be integrated into the design of open space areas helping create a larger visual amenity. However, the stormwater runoff area should not

limit the use of open space and shall not count towards the required open space.

- Where possible existing natural features should be incorporated into the design and programming of open space.
- Common facilities such as laundries, mailboxes, and management offices should be planned in conjunction with open spaces and the circulation system so that they are conveniently located for most residents.
- Upper-level private open spaces shall look out on streets, alleys, paseos or common open space areas.
- All multi-family projects shall provide open space amenities to meet the active and passive recreation needs of the community they serve. The number, type and size of amenities should be proportional to the anticipated number of future residents and representative of the anticipated needs of the future residents. Compliance with this guideline will be evaluated on a case-by-case basis as part of the required Design Review with the intent of establishing a selection of one, or a combination of multiple amenities, that are appropriate in size, type, and use to the community residents of each project. Amenities may also be located on podium tops or roof decks and will be counted toward common open space requirements. Amenities shall be centrally located for most residents



*Example of common open space with passive and active areas*



*Private open space may include above ground private decks/balconies*

and may consist of one, or a combination of multiple amenities listed below:

- Tot lot/play structure.
- Community garden.
- Picnic tables and BBQ areas (preferably with shade structures).
- Swimming pool.
- Sports courts (e.g. tennis, basketball, volleyball).
- Lawn;
- Dog Park;
- Natural open space area with benches/ viewing areas and/or trails.
- Other active or passive recreation area that meets the intent of this guideline.



Example of a sports courts as an amenity



Example of a courtyard incorporating a variety of open space amenities



Example of bocce ball integrated into the community courtyard



Example of stormwater facility integrated into outdoor open space



Example of a community garden as an amenity



Incorporating a dog park within a project as an amenity



Centrally located swimming pool



## C. ACCESS AND CIRCULATION

The City encourages development of multi-family sites with an integrated circulation system that accommodates all modes of transportation. Walking and non-vehicular modes of transportation shall be emphasized by providing a safe and convenient path of travel through the community. The circulation system shall be designed keeping in mind the key components listed below:

- New multi-family developments shall connect to surrounding neighborhoods with streets and or bike or pedestrian connections.



*Example of a project pedestrian facility connecting to a city-wide system*

- To the greatest extent possible, the development shall provide for future connections to adjacent parcels.
- Internal streets and driveways within projects should be designed as an integrated network of easily navigable streets so that a resident or visitor can easily enter the site, park their car, and find a particular unit.
- Interior streets shall be designed to allow for looping.
- Projects shall be designed with an internal pedestrian and or bicycle system that provides access to individual units, common areas and off-site connectors.
- If the project is located adjacent to a trail or bike route, then the project shall provide connections to those facilities. The pedestrian/bicycle network may be designed as a street adjacent system, or as a separate network that complements the street network with access to the project from primary street frontages at intermittent locations as deemed appropriate.
- Traffic calming features, such as on-street parking, one-way streets, bulbouts, raised table tops and crosswalks shall be implemented.
- The use of special paving that incorporates changes in material, color, and/or texture shall be utilized to highlight certain areas of importance, for project identity, wayfinding or

for traffic calming. Examples of locations where the special paving may be used include: project entryways, pedestrian crosswalks, pedestrian walkways and common open areas.

- Low Impact Development (LID) techniques for stormwater treatment in the design of the streets and the circulation system when used shall comply with EGMC Chapter 15.12.



*Example of narrow one-way street within a multi-family project used for traffic calming*



*Example of special paving at pedestrian crossings for traffic calming*



### D. PARKING

Parking in multifamily developments shall be designed and located conveniently to the residential units without being visually dominant. The following guidelines apply:

- Surface parking areas for resident and visitor parking shall be designed as a series of smaller parking fields, rather than one or more large fields. Multiple smaller parking lots are preferred as they minimize the expansive appearance of parking fields and provide diverse access between parking spaces and corresponding dwelling units.
- Design and locate parking areas such that the walk from the designated parking to the dwellings is short and direct, for both residents and visitors.
- All resident and visitor parking spaces shall be clearly identified.
- Dead end drive aisles shall not be longer than three hundred (300) feet.
- Where parking spaces are within fifteen (15) feet of residential units and directly front on to them, a landscape buffer of at least three (3) feet tall shall be provided to reduce the impact of headlights on the units.
- Storm water treatment shall be integrated in the design of the parking lots in compliance with EGMC Chapter 15.12.

- Use of pervious materials in parking areas is promoted, consistent with the appropriate soils being present.
- Individual garages shall not be directly accessed from public streets. This does not apply to common garages as in a podium building nor to triplexes or townhome type units. Front loaded triplexes or townhomes shall have a minimum of eighteen (18) foot driveway apron and the garage door shall be setback at least the same distance as the livable portion of the house or a porch.
- Garages (individual or common) visible from public streets or open spaces, shall be screened through fences or landscape.



Example of a smaller parking field that has direct and clear access to the building entry

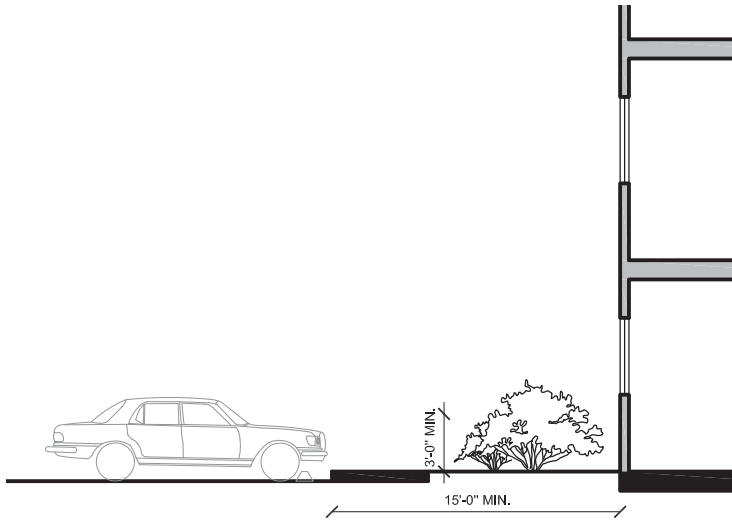

Minimum three (3) foot high landscape buffer required in front of parking spaces within fifteen (15) feet of units



Techniques for stormwater treatment shall be utilized

## E. LANDSCAPING

Landscaping shall be designed as an integral part of the overall site plan with the purpose of enhancing building design, framing public views and spaces, and providing buffers, transitions and screening. Landscaping can also serve to filter and infiltrate storm water runoff to reduce adverse environmental effects. Additionally, the City requires the use of drought tolerant vegetation consistent with the City's adopted Water Efficient Landscape (EGMC Chapter 14.10) regulations. Provisions related to the landscaping for treatment of landscape corridors, perimeter landscape, internal landscape, and project entries are listed below.



*Example of the use of accent trees to screen units*

### E.I. LANDSCAPE CORRIDORS

- Landscape corridors shall be provided along arterial/thoroughfare and collector streets as per the municipal code. However, the City may allow reductions in the landscape corridor width of arterial/thoroughfare or collector streets to ensure continuity with the size and character of an existing approved corridor.
- Landscape corridors along multi-family developments shall enhance surrounding developments, create a pedestrian friendly environment, and establish year-round and seasonal landscape to soften the appearance of streets.
- Street trees shall be planted in a single row, appropriately set back from the back of curb and concrete sidewalks/driveways. For streets with detached sidewalks or planting strips between the sidewalk and a sound wall, trees shall be planted centrally in the planter.
- Accent trees are intended to supplement and enhance the street trees. Accent trees should have distinguishing characteristics (color, shape, texture, and flowering pattern) to highlight significant areas within the neighborhood as wayfinding elements. (e.g., points of entry, pedestrian access points, intersections, transitional areas, and bus shelters).

- Both street trees and accent trees should include varieties that provide for screening and canopy while also providing year-round interest and seasonal changes through the careful use of flower and leaf color. Therefore, such trees can be deciduous or evergreen.
- Shrubs and groundcover shall be designed to enhance the character of the neighborhood. Landscape considerations should include visual appeal (e.g., flowers, foliage, and form) and function (to maintain vehicle sight, conceal masonry walls, and utilities/equipment).
- Landscape should emphasize the use of drought-tolerant, indigenous and native-adapted landscape species.



*Example of groundcover variety to create year-round interest*



E.II. PERIMETER LANDSCAPE

- Perimeter landscape areas shall be designed in response to the surrounding context. Where necessary, landscaping shall be used to maximize screening and buffering between adjacent uses.
- Privacy shall be maximized between multi-family and adjoining single-family development. This may be achieved by including initial large plantings of 24-inch box trees, clustering of the plantings, or the use of evergreen trees.
- Landscaping shall be used to delineate project entries. Entries shall be designed as special statements reflective of the character of the development. Special accents such as scaled art or fountains, ornamental features, textured paving, flowering accents, shrubs, and the use of specimen trees shall be used to generate visual interest at these entry points. For infill locations, this may be achieved through change in paving or landscape material that accentuates the entry.



Example of the use of landscape elements to highlight entries



Example of the use of landscape elements to highlight entries



Example of the use of landscape elements to highlight entries



Example of a landscape buffer on the perimeter of the project boundary



### E.III. INTERNAL LANDSCAPE

- Landscaping shall be utilized to frame, soften, and embellish the units, to buffer the units from noise or undesirable views, to break up large expanses of parking and to ensure compatibility to provide visual screening.
- All areas not covered by drive aisles, parking or hardscape shall be landscaped.
- Accent trees shall be a minimum of fifteen-gallon size.
- Use landscaping, and building placement to create gateways to the common open space, creating a distinction between the public realm and the semi-private open space.
- Landscaping shall complement the building design in terms of placement, type and scale. The City encourages the use of landscape enhancements such as trellises, arbors, cascading landscaping, vines and low garden walls.
- The City encourages the use of Low Impact Development techniques to reduce the amount of stormwater runoff by utilizing rain gardens, bioswales, pervious paving, landscaping at downspout locations, and other innovative design features.



*Example of landscaping similar in scale to the surrounding buildings*



*Example of use of landscape to buffer units*



*Example of a clear and visible pedestrian pathway*



*Example of landscape enhancements such as trellises and large pots*



*Example of incorporation of water retention techniques such as bioswales*



### F. LIGHTING OF PARKING AREAS, DRIVE AISLES, AND PEDESTRIAN WALKWAYS

Site lighting for multi-family projects include lighting of project entries, streets, drive aisles and parking areas, pedestrian walkways, and common areas designated for regular nighttime use. The lighting Guidelines in this section are for site lighting only. Building lighting Guidelines are listed in the architecture section.

- Lighting should be designed and located in accordance with the City of Elk Grove’s Lighting Standards (EGMC. 23.56).
- Exterior lighting shall be pedestrian in scale and a maximum of fourteen (14) feet in height.
- Lighting shall be designed to minimize glare. Light features shall be located and designed with cut-off shields to minimize light pollution, protect views of the night sky and to avoid light spill and glare on adjacent properties.
- As an alternative to street lights, bollard lights or low lights attached to street furniture may be used provided they comply with the provisions in EGMC 23.56
- The color of the lighting fixtures shall be the same throughout the community. Changes in hues are allowed. e.g. different shades of the same color

- Outdoor light fixtures used to illuminate architectural and landscape features shall use a cone to confine the light to the object of interest and minimize light trespass and glare.



Example of utilizing pedestrian scaled lighting to highlight pathways as an alternative to street lights



Example of using bollard lighting to highlight pedestrian walkways to individual units



Example of downward facing cut-off lighting



## G. TRASH ENCLOSURES AND UTILITIES

Services and utilities planning should be designed and located so that they complement the site planning and other elements within of the project design. Careful thought must be given to finding the right balance between the convenience of services to the residents and visual and physical impact of these locations. Guidelines for the location and design of these of these facilities are listed below:

- Trash enclosures should be conveniently located for collections and maintenance.
- The trash enclosures shall be constructed with durable materials that are architecturally compatible with the design of the buildings. The enclosure area shall be paved, bermed and or graded in order to drain into the sanitary sewer system.
- The colors of the walls of the trash enclosure shall complement the adjacent residential units.
- Where trash enclosures are located adjacent to landscape planters, landscaping shall be incorporated around the trash enclosures to provide more effective screening.
- The location of utilities within the site should be planned in conjunction with the use and location of other amenities on the site such as open space, and storm water facilities.
- Mechanical and other utility equipment shall be screened from view of public streets, parking lots, and adjacent residential property through the use of architectural screens, landscape, or a combination of both.
- The City encourages the undergrounding of utility equipment as feasible or otherwise required. When utility equipment such as transformers, electric and gas meters, electrical panels and junction boxes are located above ground they shall be incorporated into the design of the buildings or screened by walls and/or landscaping.
- Where mechanical equipment is located on the roof, the rooflines should be designed to screen roof mounted mechanical equipment. If additional screening taller than the roofline is required then the screening material shall visually match the color of the building.
- Required common open spaces shall not be interrupted by placement of utilities. Utilities shall be located at the edges of the open spaces.



*Example of a well screened trash enclosures*



*The color and material of trash enclosures shall match the style of the buildings*



*Example of using landscaping as an alternative to shielding mechanical equipment*



### H. FENCING

Fencing can be used to demarcate areas. While the proper type and use of fencing may provide adequate privacy, excessive fencing between projects may create barriers to a cohesive pattern of development. The following guidelines apply to the use of fencing in multifamily developments:

- Low fences, low walls, or fences with landscape when placed along the front of the building and unit are allowed. These fences or walls shall not be taller than three (3) feet. The goal is to create a distinction between the public and the semi-public/private space and to balance the need for privacy, transparency and safety.
- To discourage the creation of internalized enclaves and promote a seamless integration between adjacent compatible developments, the City discourages perimeter fencing of any type along street frontages except where noise attenuation is required.
- Partial or fully open view fencing is required along interior property lines abutting open space. Solid fences taller than three (3) feet abutting open space are prohibited.



*Example of low walls at unit entires to create privacy and security*



*Example of fencing at individual yards to enclose the space and provide privacy*



*Example of open view fencing where the property abuts open space*

## 4.2 ARCHITECTURE FOR MULTI-FAMILY DEVELOPMENT

*The City's primary goal for multi-family development is to ensure a high quality residential environment. This section of the Design Guidelines will provide descriptions and options of appropriate building materials and architectural design. The design of multi-family developments shall consider the compatibility with the surrounding neighborhood. In certain cases, multi-family projects may be developed adjacent to single family neighborhoods. In these cases, steps should be taken to ensure that height and mass of the multi-family projects do not overwhelm the adjacent single-family development.*

*The intent of the architectural Design Guidelines is to encourage development that fits within, and contributes to, the established or planned architectural character and context of the area. Provided below are provisions and options to support the architecture concepts for multi-family development.*

### A. ARCHITECTURAL STYLE AND DESIGN

- All multi-development projects shall be designed with a consistent architectural theme or style, which may include a complimentary style or family of styles. That particular style shall be reflected in building form, decorative features, materials and colors.
- The design of multi-family buildings shall be varied along the public street to create visual interest. Street oriented facades shall have porches, balconies, stoops, and/or other

architectural detailing that encourage a strong visual relationship with the street.

- Where a predominate architectural theme or style exists in a neighborhood, new multi-family developments are encouraged to be designed complementary to such theme/style. The project may be designed in the same style as the existing neighborhood or may utilize architectural cues from the surrounding context such as similar materials or color tones, roof styles, and incorporation of existing design details.



*Visual interest shall be created through varied architectural elements while maintaining a consistent theme*



### B. MASSING, SCALE, AND FORM

Architectural scale, for purposes of these Guidelines, is the relationship between the size of the new buildings and the size of the surrounding building or residences. The guidelines below suggest design techniques to reduce the mass and scale of buildings to create a more pedestrian friendly and human scaled neighborhood.

- Multi-family buildings shall be designed with structural and spatial variety along the front façade by incorporating architectural projections and articulations to reduce long, continuous wall planes, and mixing the use of materials or colors. This can be achieved by incorporating a minimum of two of the design solutions listed below:
  - A façade break a minimum of ten (10) feet in width, minimum five (5) feet in depth, and a minimum two (2) story tall for every fifty (50) feet in facade length (Fig 4.2).
  - An upper story stepback a minimum of five (5) feet in depth, ten (10) feet in width and minimum one story tall for every fifty (50) feet in facade length (Fig 4.3).
  - A projection minimum three (3) feet in depth, six (6) feet in width, minimum one (1) story tall for every fifty (50) feet in facade length. The projection may be units,

decks or balconies. For balconies the one (1) story requirement is not applicable as long as the width and depth requirements are met (Fig 4.4).

- Include a minimum of two roof styles (e.g. gable, hip, shed, flat with parapets, mansard).
- Create change in roof heights by changing the roof pitches or by staggering the roof line (min. four (4) feet difference between the highest points of the roof).
- Blank walls along streets and pedestrian walkways shall be limited by incorporating windows or entries. Blank walls longer than fifty (50) feet fronting streets or pedestrian walkways are prohibited.
- Reinforce street corners with changes in architectural massing/height. The change in height shall be a minimum of four (4) feet for a minimum distance of ten (10) feet in both directions (Fig 4.5 & 4.6).

FIG 4.2: FACADE BREAK DIAGRAM

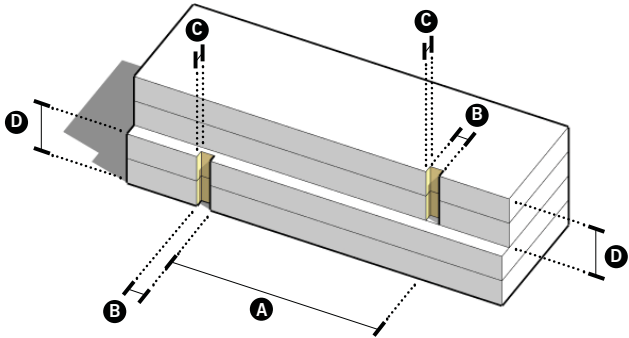

- A Facade length, maximum seventy five (50) feet
- B Facade break width, minimum ten (10) feet
- C Facade break depth, minimum five (5) feet
- D Facade break height, minimum two (2) story tall

FIG 4.3: UPPER STORY SETBACK DIAGRAM

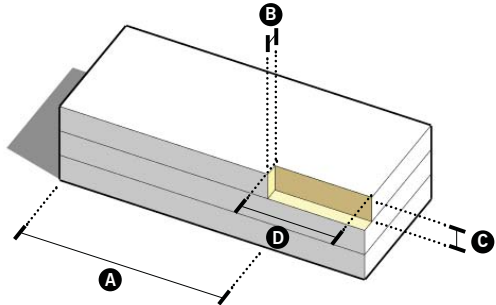

- A Facade width, maximum fifty (50) feet
- B Facade setback depth, minimum five (5) feet
- C Facade setback height, minimum one (1) story tall
- D Facade setback width, minimum ten (10) feet



## 4.0 Multi-Family Development

FIG 4.4: PROJECTION DIAGRAM

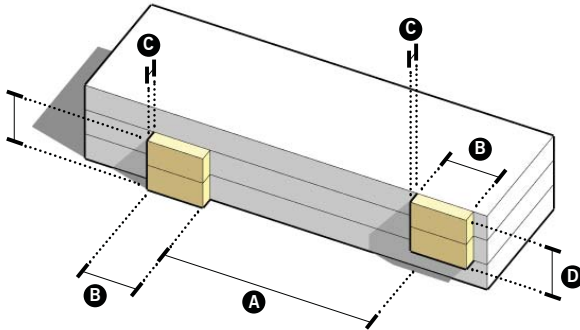

- A** Facade length, maximum fifty (50) feet
- B** Facade projection width, minimum six (6) feet
- C** Facade projection depth, minimum five (5) feet
- D** Facade projection height, minimum one (1) story tall

FIG 4.5: STREET CORNER DIAGRAM

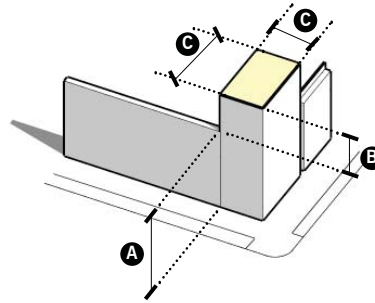

- A** Abutting primary facade height
  - B** Corner element height difference of minimum of four (4) feet or more to **A**
  - C** Corner element of minimum ten (10) feet width
- Corner element

FIG 4.6: STREET CORNER DIAGRAM

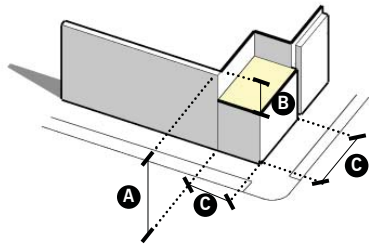

- A** Abutting primary facade height
  - B** Corner element height difference of minimum of four (4) feet or more to **A**
  - C** Corner element of minimum ten (10) feet width
- Corner element



Example of change in roof planes and roof types



Example of use of multiple roof types



Example of a facade break



Example of porch used as a ground floor projection

### C. MATERIALS AND FINISHES

Exterior building materials and colors comprise a significant part of the visual impact of a building. Significant elements such as materials and detailing used on the building elevation facing the public street should be extended to all elevations. The intent is to carry over the architectural treatments for building facades that face parking lots, streets, public or open space areas and adjacent existing development.

- At a minimum, two different primary building materials or colors shall be used on each building elevation, except for Santa Barbara Style, which allows for a single white color to be used.
- Heavier accent materials such as stone or brick materials shall be used lower on the building elevation to form the building base.
- Changes in materials and colors shall be returned to an inside corner or change in wall planes.
- Gutters, downspouts and rainwater leader heads shall be integrated into the roof/wall detailing. Exposed downspouts shall be colored to match the surface to which they are attached or to compliment such surface.
- On all elevations, openings shall be trimmed

and articulated with an appropriate head, sill and jamb detail. Colors shall be used to accentuate trim, windows, and doors.

- Garage door color shall be different from the surrounding walls to provide depth and contrast. The color of the door however may be the same as the trim surrounding the door.



Example of a variety of building materials and colors



COLOR-MATCHED DOWNSPOUTS

COLOR-MATCHED DOWNSPOUTS



NOT RECOMMENDED: Example of how colors should not terminate on outside corners



### 4.0 Multi-Family Development



Example of colors used to highlight facade breaks and architectural treatment



Example of a variety of complimentary colors throughout the project



Example of heavier accent materials such as stone and brick used lower on the building



Example of the use of garage doors to provide contrast



Example of minimum two different building materials/colors to be used



### D. BUILDING ENTRIES

Multi-family buildings have different kinds of entries: private entries to individual units (townhomes), private entries for only ground level units on multi-unit buildings (apartment type buildings) and common entries for serving multiple units (apartment type buildings). The followings guidelines are applicable for the appropriate building types:

- For buildings with both individual and common entries, there should be a hierarchy in the scale and identity of the entries. Common entries shall be larger in scale and differentiated from individual street-level unit entries with special detailing, awnings, canopies, or multi-story forms.
- Provide clearly defined site and building entries that are in scale with the proposed project and relate directly to the street frontage.
- The front door to each unit shall be clearly visible. Entries to units should be clearly identified, protected from weather and provided with lighting for nighttime safety and security.
- Entrances to individual units should be plainly visible from the nearby parking areas.
- Ground level private dwelling unit entries fronting a public street shall incorporate a porch, a stoop or a recessed entryway.
- All entries shall be weather protected.



Example of private entries when fronting on to streets



Example of individual unit entries emphasized with architectural elements such as stoops



Highlight individual unit entries with design elements and landscaping



Example of an easily identifiable main building entry



*Example of recessed entryways to distinguish individual units*



*Example of the main building entry being grander and larger in scale*

## E. BUILDING LIGHTING

- All exterior building light fixtures shall be architecturally compatible with the architectural style of the building.
- Apart from security and safety, lighting should also be used as a wayfinding technique to provide a clear and distinct path from roads, walkways and parking lots to entries.
- Lighting shall be designed to minimize glare. Use downward directing lighting fixtures with cut-off shields to minimize light pollution and protect views of the night sky.



*Example of building lighting to highlight specific building components*



*Example of building lighting being compatible with the architectural style*



### F. SIGNAGE

- Sign type, size and location for multi-family residential development projects shall comply with applicable sign provisions in the Zoning Code. Additionally, directional signs shall follow the standards as set forth in the Fire Code.
- A minimum of one directional sign is required for multi-family projects with more than one building. Such signs shall be designed to be compatible with the design, colors, and materials of the project. Directional signs shall be internally illuminated.
- Sign type, size and location for multi-family residential development projects shall be compatible with the architectural style of the project.
- Signage relating to buildings and individual units shall be located so that they are visible from project entry, streets, walkways, or parking lots.
- There shall be a hierarchy in the scale of signage provided. The building signage shall be larger and prominent than the individual unit signage.



Example of signage located along a public walkway

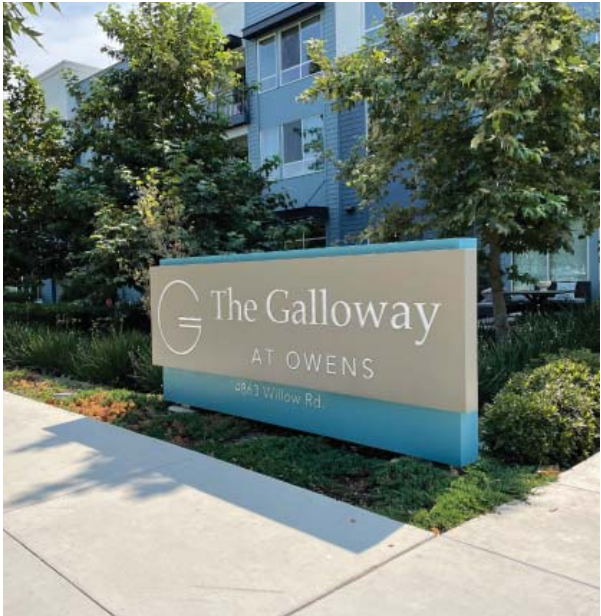

Example of main signage that is easily visible



Example of a building signage fronting the street



Example of signage at project entryways as a wayfinding mechanism



## G. ADDITIONAL GUIDELINES FOR VERTICALLY MIXED-USE BUILDINGS

These Guidelines apply to vertically mixed-use buildings that include residential use as one of the uses. The primary design issue related to mixed-use projects is the need to successfully balance the requirements of residential uses, such as the need for privacy and security, with the needs of commercial uses for access, visibility, parking, loading, and possibly extended hours of operation. These guidelines are specific to vertical mixed-use buildings are in addition to the other Guidelines listed in this chapter.

- Mixed-use buildings shall be sited and oriented so that the primary commercial building entry is located along the public sidewalk.
- Mixed-use buildings shall have independent and clearly demarcated entries for the different uses.
- Ground floor heights in mixed-use buildings shall be a minimum of fifteen (15) feet. The required ground floor height is the clear height measured from first floor to the bottom of the plate of the second floor.
- Primary commercial/non-residential entries shall be accessed directly from the primary street's sidewalks. Secondary and service

entries for the commercial/non-residential and residential entrances may be accessed from secondary streets or interior courtyard or parking lots.

- Active ground floor uses such as storefronts and lobbies shall front the public sidewalk.
- Parking shall be located to the rear of the site in a parking lot, within the building, or in a separate structure.
- Open space for the residents shall be provided separate from any open space that also serves non-residents.
- Open space for the residents may be located on the ground or above ground on a podium or on as a roof top.
- Open space designated for non-residential uses may be used by residents.

- A minimum of fifty percent of the residential units overlooking the primary street on which the non-residential uses front on to shall have balconies along that facade



*Storefront and lobbies shall front the public street*



*Non-residential entries shall be directly accessed from the street*



*Residential balconies overlooking the primary street*



*Resident amenity may be located on top of a podium*



*Ground floors shall be a minimum fifteen (15) feet tall*



*Storefront and lobbies shall front the public street*



*Parking shall be located towards the rear of the building*

This page is intentionally left blank



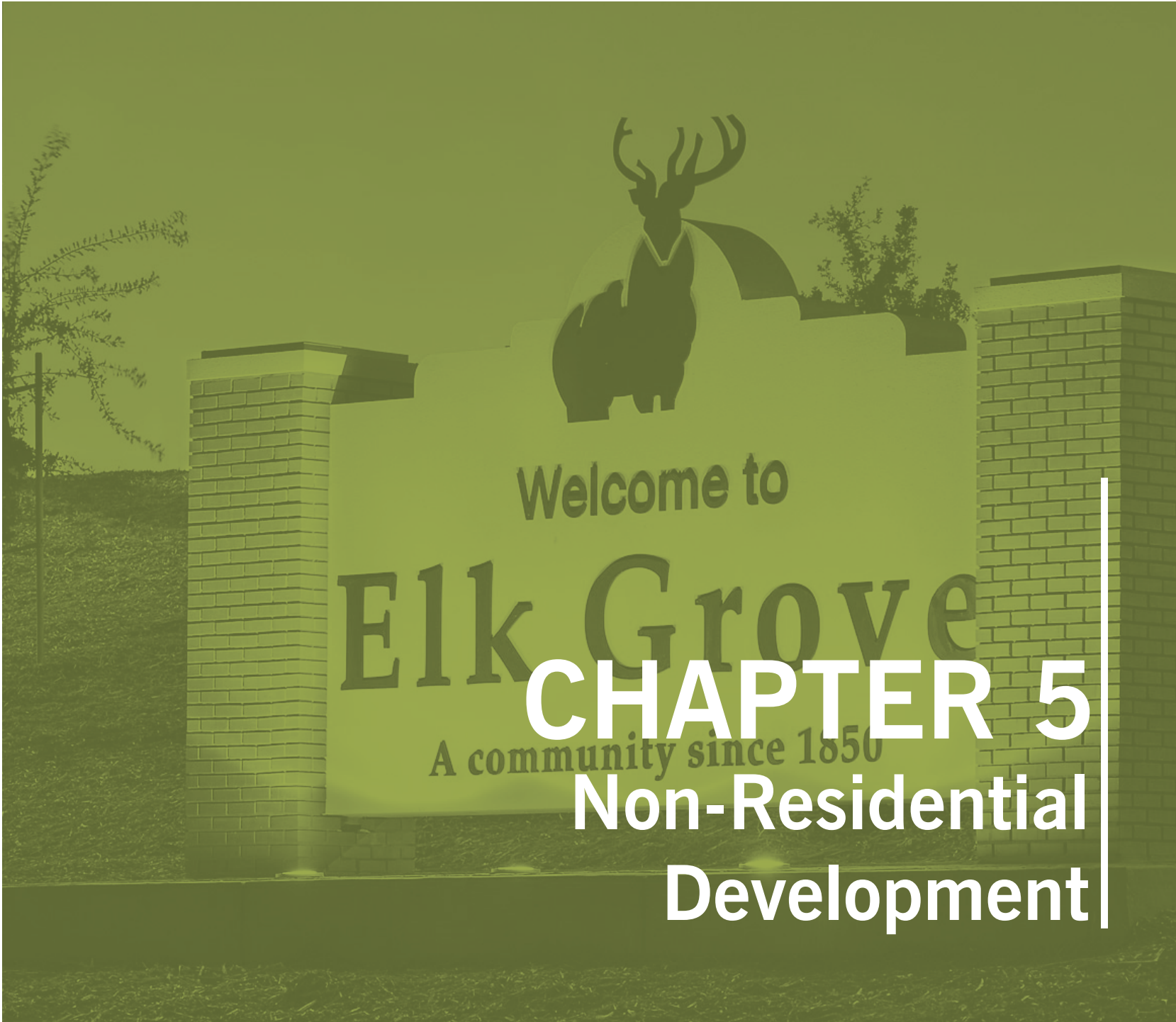

**CHAPTER 5**  
**Non-Residential**  
**Development**



## 5.0 INTRODUCTION

*This section of the Design Guidelines applies to all non-residential development including retail and service commercial, office, industrial and quasi-public development unless otherwise specified. For horizontal mixed-use projects the non-residential guidelines apply to the Non-residential uses and the multi-family residential guidelines to the residential portions of the development. Guideline applicability is based on the type of use/development proposed and not on the zoning district. Guidelines in this section include a mix of menu, target, required and encouraged provisions as appropriate and desired.*

*This chapter is divided into two main sections: (5.1) Site Planning, and (5.2) Architecture for Non-Residential Development. Section 5.1, Site Planning, identifies desirable characteristics in relation to specific site development guidelines. Section 5.2, Architecture for Non-Residential Development, contains guidelines relating to the architecture of the buildings themselves. Guidelines herein are intended to supplement the minimum development standards in the Zoning Code.*

*Through adoption of these Guidelines, the City establishes the requirement for quality design of nonresidential development. In summary, the Guidelines in this chapter are intended to:*

- ***Encourage development that is sustainable, functional and attractive.***
- ***Ensure that developments address all improvements such as streetscape, public realm, high quality architecture, and appropriate to the scale, scope and location of the project.***
- ***Ensure that new development creates a sense of place by enhancing the community character and providing economic vitality of the community.***
- ***Ensure compatibility with surrounding uses.***
- ***Promote context sensitive theming of projects while allowing for incorporation of corporate architecture to blend with the project theme.***
- ***Design projects to be appropriate to both pedestrian and vehicular use.***
- ***Provide design flexibility for mixed-use development that ensures compatibility with the existing and new development.***

*The Design Guidelines are approaches to meeting the intent of the design concepts. The text, figures, and photographs are presented as examples, but do not illustrate all possible solutions applicable to all situations. There may be alternative approaches that, in a set of circumstances, could be a more appropriate way to meet the principle. The City recognizes that each project must be considered individually, and is committed to a collaborative review process that has the shared objective, between project proponents, project reviewers, and other interested parties of ensuring enduring and sustainable commercial areas and promoting quality design.*



## 5.1 SITE PLANNING FOR NON-RESIDENTIAL DEVELOPMENT

*For the purposes of these Guidelines, site planning is the analysis and resulting design of land that takes into consideration site conditions, surrounding uses, and development opportunities to determine the physical, functional, and visual plan for the development of said property. The following Guidelines are supplemental to the Zoning Code and are intended to facilitate good design practices for non-residential development.*

### A. BUILDING PLACEMENT & SITE ORGANIZATION

Building placement and configuration on all non-residential sites shall take into consideration the physical use, functionality of users (both vehicle and pedestrian), and visual impact and experience for users and passersby and the context of its location. The relationship of the organization of the site with the building placement must address the overall context of the surrounding environment, consistency of the streetscape, and potential impacts to the existing and planned adjacent uses.

- Development should promote the extension of the public realm, pedestrian connections and circulation patterns.
- Development should respect the privacy and solar access of adjacent uses through appropriate siting of structures. The orientation of buildings and outdoor spaces should consider the effect of sun angles/climatic conditions and existing desirable views.
- Developments should respect and respond to the natural site characteristics with efforts made to integrate the natural features of the site in the design and planning of the development. Significant natural features include, but are not limited to, protected trees/tree clusters, topography and creeks. The natural features may be integrated into the design creating a strong focal element or be used a visual amenity.
- Where pedestrian-oriented storefronts exist or should be established, the character of the street as a shopping area should be expressed by features such as display windows, individuality of shop frontages, colors, awnings, canopies and signage.
- When buildings back on to the public streets, monotonous building façade(s) shall be avoided. Buildings shall be buffered from the sidewalk by landscape and shall be designed to the same amount of architectural detail as the front of the buildings. The building facade variation maybe achieved by change in building plane and rooflines, color and material changes, incorporation of windows and display signage etc.
- Buildings and/or building entries should be oriented towards the primary nearby street. Large setbacks behind vast expanses of parking should be avoided.
- Clearly delineated pedestrian access within the development and from adjacent uses through signage and landscape treatments shall be provided.
- Buildings should be logically placed in an arrangement that provides functional private and public outdoor spaces, which may include entryways, courtyards, sidewalks, and patios.
- Parking should be designed as multiple smaller parking fields. Large areas of uninterrupted

parking along non-residential street frontage should be avoided.

- Locate structures to create continuity of frontage along the street face.
- For retail and service commercial, office, and community facilities with multiple structures or tenants, the City encourages incorporation of the “village” design concept. Specific characteristics include:
  - Cluster the buildings in a manner that creates an integrated pedestrian network with parking that is shared between uses.
  - Parking is secondary to the development and is located behind buildings or contained in a section within the site.
  - Pedestrian circulation shall be the main focus of the development and should be integrated with the site layout, uninterrupted



*Corner Plaza as a gateway element*



*Avoid blank walls fronting on to public streets through landscape and building articulation*



*Individuality of stores expressed through signage, colors and shop frontages.*



*Accentuated and clearly defined pedestrian access through the site*



by vehicular circulation or parking lots.

- There should be a central core to the development that promotes a variety of activity and uses such as passive and active recreation, open space to provide opportunity for social interaction, and an area to provide a sense of place to the development.

## B. CIRCULATION

Non-residential development should provide a balanced circulation system that accommodates all modes of transportation. The system should focus on minimizing areas of conflict between the different modes with an emphasis given to the safety, and convenience of bikes and pedestrians. Vehicular circulation in non-residential developments primarily include customers, employees, and service vehicles for deliveries and trash removal. Pedestrian circulation involves the movement of pedestrians whereas alternative modes include the movement of bicycles, scooters, and any other mode beyond those of vehicles and pedestrians.

### B.I. VEHICULAR CIRCULATION

- Driveways, parking lots, and access routes should be consolidated whenever feasible to limit curb cuts, minimize development costs, and reduce auto/pedestrian conflicts.
- Access and circulation entering and leaving the development should be clear, well-articulated and provide the user visual cues for ingress and egress to the site.
- There should be clear direction, through various wayfinding techniques, to provide the visitor where to go, park their car, pick up trash or make deliveries.
- Where practicable and appropriate, connections between adjacent non-residential developments should be provided so that vehicles will not have to re-enter public streets.
- Service truck access should be separate from access points of customers and employees.
- Highlight project entryways drives and parking court entries by using landscape, texture or change in materials.
- Traffic calming measures such as roundabouts, change in materials, or narrow streets shall be incorporated wherever possible, as determined by the City.



*Example of a roundabout used as a traffic calming measure*



*Service truck access should be clearly defined for ease of circulation*



*Clear direction should be provided to enter and leave the development*



## B.II. PEDESTRIAN CIRCULATION

- Pedestrian planning should provide for easy access to public bicycle/pedestrian ways, nodes, neighborhood centers and transit stops.
- Pedestrian routes should be as obvious, direct, and simple as possible. Pedestrian routes may include separate walkways along storefronts connecting all entrances, public sidewalks or a combination of both. Pedestrian routes should be designed to discourage landscape damaging shortcuts.
- Conflict between all modes of transportation shall be minimized while pedestrian convenience and walkability should be maximized.
- Pedestrian walkways should connect each primary entrance of a commercial building to adjacent parking lots, structures, or site amenities and public sidewalks.
- Large non-residential projects should incorporate multiple points of pedestrian access. Such access shall be distinct from the vehicle access and visibly delineated.
- Pedestrian access may also be provided between buildings.
- Appropriate locations for pedestrian access points include signalized intersections, transit stops, or other designated pedestrian crossings (e.g., crosswalk, pedestrian bridge).

- Internal pedestrian walkways shall be distinguished from driving surfaces through the use of raised sidewalks, special pavers, bricks, and/or scored/stamped concrete/ asphalt and shall comply with ADA requirements.



*Raised crossings (tabletops) or change in material to highlight pedestrian crossings are encouraged in front of major entries*



*Incorporate a change in material or pattern to highlight pedestrian routes through drive aisles*



*Incorporate clearly defined and direct pedestrian access to parking lots*



*Incorporate a safe and defined pedestrian path between buildings*



*Incorporate opportunities for pedestrian relief in large parking lots*



### III. ALTERNATIVE MODES

- Where the proposed development is adjacent to compatible uses or a larger pedestrian/bike network, the proposed circulation should provide a seamless and convenient connection to the surrounding circulation network. Examples of connective elements include:
  - Shared circulation elements;
  - Pedestrian walkways or multipurpose paths;
  - Common landscape areas;
  - Privately owned public accessible open spaces area; and
  - Other design features that allow/encourage two-way access between uses.
- Where possible provide designated paths for alternative modes of transportation, such as separate sidewalks, street bike lanes.
- There should be clear direction, through various wayfinding techniques, to provide the visitor where to go and park their bicycle.



*Designated paths connect to the surrounding circulation network*



*Designated paths for pedestrians*

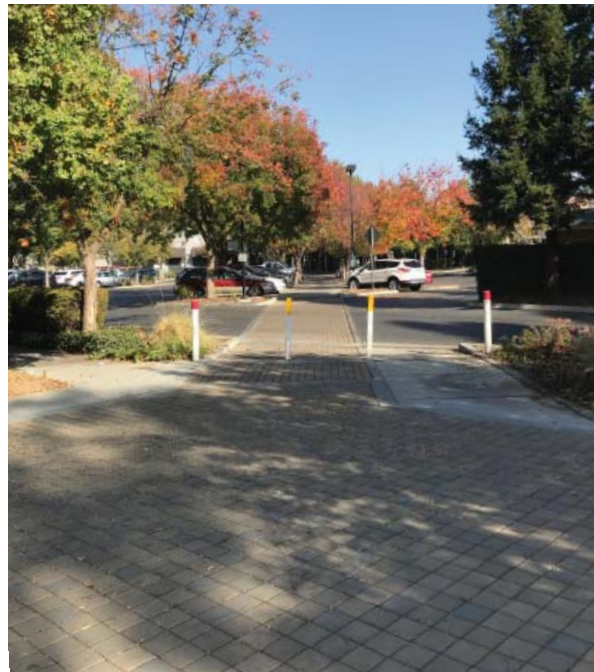

*A seamless connection to a larger pedestrian/bike network should be provided*



*Circulation should connect to the surrounding circulation network*

## C. PARKING

In order to ensure the success of non-residential development, the City recognizes the need for sufficient vehicle parking. However, the City has to balance those needs with the desire to minimize the negative aesthetic associated with a vast sea of parking between non-residential buildings and the street. A well-designed parking lot can accommodate safe and efficient movement of vehicles and pedestrians while resulting in an aesthetically appealing site with less impervious surface and increased storefront visibility. Guidelines herein restate applicable parking lot development standards from the City's Zoning Code and supplement those standards to reflect the desires of the City.

### C.I. AUTOMOBILE

- Surface parking should not dominate the frontage of the development and visual character of the site.
- In infill locations, locate parking behind or to the side of buildings rather than along street frontages.
- Parking areas should be screened using landscaping plants, berms, partial walls or other architectural features
- Collective and shared parking areas are strongly encouraged. Large surface parking areas should be designed as a series of connected smaller parking fields.
- Smaller parking fields should be incorporated by physically separating parking areas with buildings or plazas, and may be delineated with an on-site circulation system that utilizes uninterrupted drive aisles, mostly contiguous landscape planters, pedestrian walkways, or any combination thereof.
- Where possible, parking lot access should be provided from side streets to minimize the visual impact and presence of vehicles.
- Electric charging stations in parking areas should be located so that they are easily accessible by all users. Potential locations could be close to building entries for single buildings or clustered together in a central location.



*Parking should be screened using appropriate landscaping*



*Larger parking fields should be broken up with landscape planters*



## 5.0 Non-Residential Development



*Incorporate landscape elements to break up large parking fields*



*Electric Vehicle (EV) charging stations and bike lockers within parking lots*

- Parking areas should be adequately lit for a safe environment but should avoid glare that affects adjacent properties.

### II. ALTERNATIVE MODES

- A clearly defined pedestrian path inside the parking area that provides safe and easy access to and from buildings as well as sidewalks should be provided.
- Designated pedestrian access shall be provided from all parking fields to the primary building entrances.
- Adequate bike storage facilities such as racks and bike lockers should be located close to building entries.
- Bike/Scooter storage areas or share stations should not impede with pedestrian traffic or create conflicts with other major streetscape elements such as bus stops, hydrants, loading bays, etc.
- Bike/Scooter storage areas or share stations should be placed in ways that enhance the quality of the surrounding pedestrian environment.
- Bike/Scooter share stations should be protected from vehicular movement through traffic control treatments such as reflective paint and striping.



*Bike parking should be easily accessible to the buildings*



*Bike/Scooter share stations should not impede with pedestrian/vehicular traffic*



*Designated pedestrian access from parking building entrances*



## D. LANDSCAPE

Landscaping should be designed as an integral part of the overall site plan with the purpose of enhancing building design, public views and spaces, and providing buffers, transitions, and screening. Landscaping can also serve to filter and infiltrate stormwater runoff to reduce adverse environmental effects of urban runoff. Guidelines herein include streetscape, parking lot, project entry landscaping, landscaping for plazas and community spaces, walls and fencing, and building edges.

### D.I. STREETScape + PEDESTRIAN WALKWAYS

- Streetside planting along non-residential developments should enhance surrounding improvements, create a pedestrian-friendly environment, and establish year-round and seasonal landscape to soften the appearance of streets.
- Except as otherwise provided for in an adopted Specific Plan or Special Planning Area, landscape guidelines for thoroughfare, arterial, and collector streets shall be as per the City's improvement standards.
- Street trees should be the primary delineators within the landscape corridors, which aesthetically create rhythm and soften the environment along street corridors.
- Street trees should serve to provide shade, scale the environment to the pedestrian, and to define an image.
- There should be a unifying scheme of street trees to unify all the elements within the landscape corridor.
- Accent trees are intended to supplement and enhance the street trees and should have distinguishing characteristics to highlight significant areas within the landscape corridors (e.g., points of entry, pedestrian access points, intersections, transitional areas, bus shelters).



*Street trees should create rhythm, provide shade, and scale to the pedestrian environment*



*Accent trees should be used to highlight areas such as pedestrian access points*

## 5.0 Non-Residential Development

- Both street trees and accent trees should include a combination of evergreen and deciduous trees for screening, canopy, and seasonal change.
- Shrubs and groundcover shall be designed to enhance the character of the non-residential development. Landscape considerations should include visual appearance, parking lot screening, clear sight visibility at driveways and pedestrian connections, absorption of stormwater runoff, and implementation the City's current Water Conservation Ordinance.
- Landscaping should blend with the dominant existing or planned streetscape and character of the area.
- The landscape palette should introduce a variety of color, texture and softness to the project.
- All pedestrian routes adjacent to landscape planters should be designed to be visible and convenient in order to eliminate "short cuts" which damage landscape areas.



*Pedestrian routes should be provided to eliminate short cuts*



*Techniques to absorb stormwater runoff shall be incorporated*

### D.II. PARKING LOT LANDSCAPE

- Landscaping shall be provided adjacent to and within parking areas to screen vehicles from view and to minimize the expansive appearance of parking lot fields.
- Landscaping within and around parking areas should be designed in a manner to reduce urban runoff. Planter areas and plantings shall comply with minimum requirements in the Zoning Code for parking lot planting.
- Landscaping along the perimeter of nonresidential parking should be designed with plants, berms, low walls, or any combination thereof, to create a partial visual screen for the parking lot from adjoining streets to a minimum height of three (3) feet.
- Within the required clear visibility area at the intersections of streets and driveways, the maximum height of landscaping shall be comply with the City of Elk Grove's clear-vision triangle requirements.
- Trees and landscape shall be used to highlight pedestrian pathways and provide year round shade
- Trees, along with groundcover or shrubs should be used on parking lot edges to provide buffer between parking areas and sidewalks.
- Required parking lot landscape should be designed to provide visual relief from long



expansive rows of parking aisles through the intermittent use of contiguous landscape planters along parking aisles and/or pedestrian walkways.

- Contiguous planters should be designed with periodic “cut throughs” at grade to allow pedestrian and shopping cart crossing.
- Trees and landscaping installed in parking lots shall be protected from vehicle damage by a minimum six-inch tall concrete curb surrounding the planter area.
- Planter barriers to protect landscaping should be designed with intermittent curb cuts to allow parking lot runoff to drain into landscape areas.
- The landscape palette should introduce a variety of color, texture and softness to the project.



*Trees/shrubbery shall provide a buffer from the parking lot and sidewalks*



*Trees shall be protected from vehicle damage by a minimum six-inch curb*

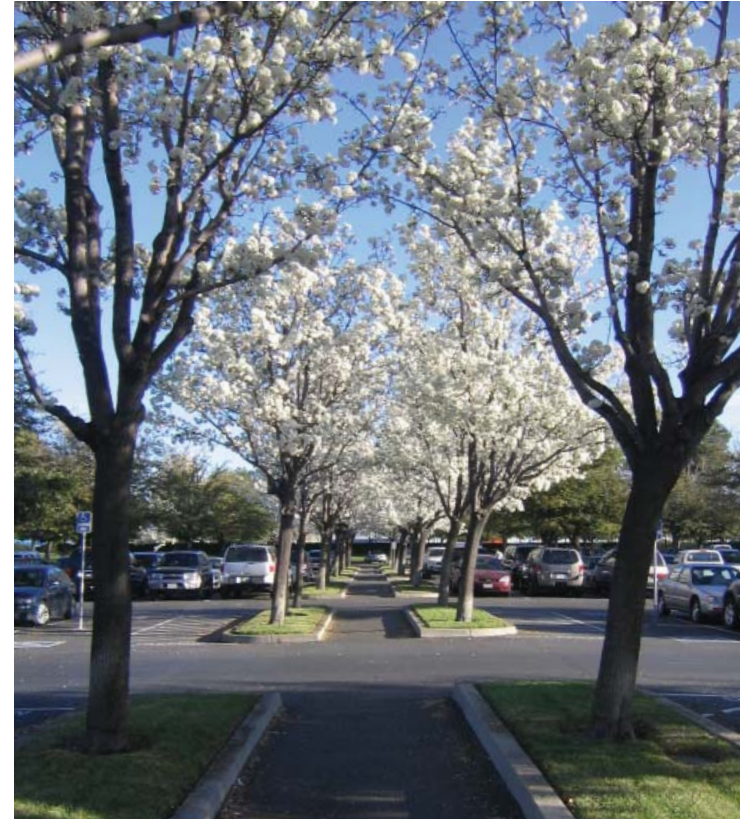

*Parking lot trees shall highlight pedestrian walkways and provide year round shade*

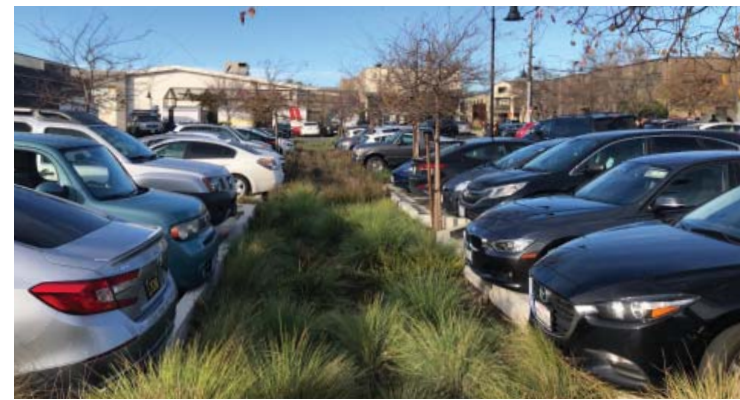

*Incorporate catchment areas where applicable to reduce impacts of paving*



### D.III. PROJECT ENTRY LANDSCAPE

- The use of landscaping and accent paving can help define and beautify a project entrance as viewed from the street.
- The vehicular entrance to the project should be clearly defined and provide adequate sight distance for vehicles and pedestrians.
- Entries to multi-tenant projects shall be designed as special statements reflective of the character and scale of the project in order to establish identity for tenants, visitors, and patrons.
- Landscape design at project entries shall compliment the special landscape treatment at street corners with common elements. Flowering accent plantings and specimen trees shall be used to reinforce the entry statement.
- The landscape palette should introduce a variety of color, texture and softness to the project.
- Projects located at street corners should provide special landscape treatment at street intersections to anchor the corner, enhance the pedestrian environment, and establish continuity along landscape corridors for community identity.



*Project gateways shall be visible from the street*



*Project entries may be highlighted by special landscape treatment*



*Gateway signage material shall be consistent with the design of the project*

### D.IV. LANDSCAPE FOR PLAZAS AND COMMUNITY SPACES

- Encourage, as appropriate, that building and site design include use of pots, vases, wall planters, and/or raised planters, as well as flowering vines both on walls and arbors.
- Landscaping should be provided that enhances the project aesthetics by softening building elements, breaking up hardscape, and providing buffer between uses.
- All planting materials should be sized so that landscaping has an attractive appearance at the time of installation and an established appearance within approximately three years of planting.
- The location should be convenient to most users and the design should accommodate spaces to gather, formally or informally in all times of the year through the use of materials, site furniture, and planting.
- Design and layout of plaza areas should consider the local climate and seasonal conditions, shadows and glare from adjacent buildings and provide protections from the natural elements when required.
- Site furniture should be selected not only for its functional and aesthetic qualities but also for the quality of materials and finishes that provide long term durability and resistance to vandalism and climate/sun damage.



- The use of native, drought tolerant planting, and incorporation of Low Impact Development techniques in the design of these spaces is highly encouraged.
- The landscape palette should introduce a variety of color, texture and softness to the project.
- Unpaved areas should be planted with irrigated plant materials. Where landscaping in unpaved areas proves challenging, or does not meet the desired look and feel of the project, the area should incorporate mulch, decomposed granite, or the like to minimize weed growth and add the appearance.



*Incorporate site furnishings such as chairs and benches*



*Public art in plazas shall compliment the design of the project*



*Raised planters, pots, and other design elements are encouraged in plazas*

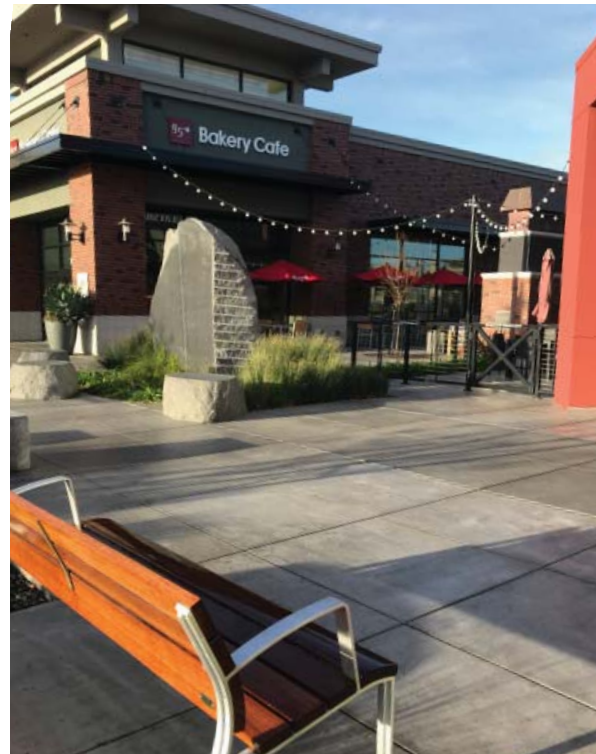

*Plazas shall provide areas for users to congregate*



*Unpaved ares should be planted with irrigated plant materials*



### D.V. LANDSCAPE FOR BUILDING EDGES

- Landscaping along the adjoining property lines should be appropriately selected to provide for year round screening. Where additional height of screening is required berms may be used in conjunction with screening planting.
- Landscape screening shall be provided between open spaces and non-residential uses.
- The landscape palette should introduce a variety of color, texture and softness to the project.
- Raised planters are acceptable when designed to accentuate the architecture and or enhance pedestrian areas.
- Provide deciduous shade trees along the south and west sides of the buildings and all paved areas to reduce heat transmission.
- Landscaping should be appropriately scaled and compatible with the building design and not compete with the architecture, rather complement the style.
- Landscaping should be provided that enhances the project aesthetics by softening building elements, breaking up hardscape, and providing buffer between uses.



*Provide landscape screening when non-residential abuts open space*



*The landscape palette should incorporate a variety of color, texture, and softness*



*Incorporate a solid wall where non-residential uses abut residential uses*



*A landscape buffer should be provided between two different uses.*



*Large blank walls may include vines to soften the aesthetics*



## D.VI. WALLS/FENCING

- Walls/Fencing shall be installed in compliance with the Zoning Code. The design of all proposed walls and fencing along property lines, delineating uses, storage, or outdoor seating will be reviewed as part of the Non-Residential Design Review application.
- The location, height, materials and finishes should be appropriate for the purpose of the barrier and should complement the building design.
- The design of solid walls abutting residential development or property shall include a trim cap.
- Solid walls shall be designed to be resistant to graffiti.
- Fencing between open spaces and non-residential uses shall be open fences. The design of the fences shall be integrated with the character of the overall development.
- Walls or landscaping shall be used to buffer drive-throughs and menu boards, especially where the drive-through is adjacent to a roadway.



*Height, materials, and finishes should be appropriate to the project*



*When adjacent to residential, walls shall include a trim cap*



*Open fencing shall be used when the project is adjacent to open space*



*Shield drive-throughs from public streets by using landscaping or a wall*



*Walls can lower the impact/appearance of a drive-through*



## E. TRASH, MECHANICAL EQUIPMENT, LOADING AND SERVICE AREAS

Service elements and infrastructure such as trash/recycling enclosures, mechanical equipment and loading and service areas are a key component to the functionality of the development. Unsightly and poorly located service elements can detract from the visual appeal of the design and streetscape, increase visual clutter, and create hazards to pedestrians and vehicular traffic. While these may not be the most attractive components to the design of the building, certain measures should be taken in order to make sure the impacts of such components are lessened and high quality design is maintained. With proper design techniques, these impacts can be mitigated and made less obtrusive if the following guidelines are met. The following provisions do not apply to industrial developments.

### I. TRASH AND RECYCLING

- Trash/recycling areas shall be screened from public view
- Screening may be achieved through enclosures, fencing, planting or a combination of these techniques.
- Trash enclosures and containers shall be sized to accommodate the types and volume of refuse but should also take advantage of opportunities to centralize enclosures where there are multiple buildings or users.
- The City discourages use of hydraulic compactors except where entirely enclosed within a building. If located outside, compactors shall be visually and acoustically screened to minimize hydraulic noise impacts to surrounding and nearby residents.
- Trash enclosures shall be constructed of durable materials such as split face block, brick, stucco over block, or similar quality. The materials and colors shall be consistent with and complimentary to the style and character of the buildings.
- The City encourages placement of trash enclosures adjacent to landscape planters to provide the opportunity for landscape screening, particularly where visible from adjacent residential property.
- The location and access route to the trash



*Color and materials shall be consistent with the primary structure*



*Proper screening techniques may include landscape screening*



*Trash enclosures shall be complimentary to the style and character of the buildings*

enclosure must be considered in the site design for the convenience and safety of the users and the solid waste personnel.

- All materials used for sidewalk, access to bins, and driveway access shall be flat to ease of hauling of the containers.
- All screening should be unobtrusive with pedestrian and vehicular traffic.



*Trash enclosures shall have a clear path of travel for ease of access*

## II. MECHANICAL/UTILITY PLACEMENT

- Mechanical and utility equipment should be screened from public view, including the streetscape if applicable. Screening may be achieved through enclosures, screens, fencing, planting, incorporating it as a part of the building or a combination of these techniques.
- Ground mounted utility equipment such as transformers, electric and gas meters, electrical panels and junction boxes should be screened by walls and/or landscaping. Where possible they should be integrated to the building design, or clustered in less prominent locations away from public rights-of-ways.
- Mechanical equipment (heating, cooling, antennas satellite dishes, air conditioners, or similar) located on buildings should be integrated into the architectural design of the project as much as possible.
- The location of mechanical and utility equipment shall be unobtrusive with pedestrian and vehicular traffic.
- Mechanical equipment adjacent to vehicular traffic areas shall be protected from vehicular damage.
- Roof top mechanical and other equipment should be located away from public view or screened using screening materials compatible with the architectural character on the building.



*Mechanical doors should be screened (i.e. blend into the architecture)*



*Utility meters shall be screened from public view by adequate landscaping*



*Utility boxes shall be protected from vehicular damage and screened*



### III. LOADING AND SERVICE AREAS

- Sufficient space for movement and circulation of transport vehicles should be provided so they do not interfere with normal pedestrian and automobile circulation.
- Loading and service areas should be located to the rear or sides of the building (opposite the main entrance) away from the public interface. When not possible, these areas shall be screened by landscaping and/or walls to shield from public view.
- Loading docks shall provide sufficient space for the transport vehicles to eliminate interference with normal pedestrian and vehicular circulation.
- When possible, storage areas should be integrated into the building design, including architectural treatments consistent with the primary building and similar design elements or accents.
- Truck loading bays shall be adequately sized and deep enough so that transport vehicles are not parked or protrude onto the sidewalk.



*Loading and service areas shall be located on the rear/sides of the building*



*Loading docks should be adequately sized*



*Landscaping and/or walls shall be incorporated to screen from public view*



*Loading and service areas should be located away from the public interface*



*Color and material of walls shall be complimentary to the building design*



*Loading access should be separate from primary vehicular access*

## H. LIGHTING

Lighting on buildings and sites can have a dramatic effect on the mood, quality, and character of commercial districts. The color, intensity, and types of lighting used in streets, on buildings, and in landscaping contributes to the character of commercial areas. Adequate and carefully placed lighting can improve the safety and security of a site, adjacent streets, and surrounding properties. Visibility at intersections and pedestrian crossings can also be enhanced with appropriate lighting.



*Light shall be directed downward to prevent light pollution*

- Exterior site lighting shall be designed so that light is not directed off the site and the light source is shielded downward from direct off-site viewing.
- Exterior lighting shall be architecturally integrated with the overall architectural character of the development. The scale of the lighting should be appropriate to the area to be illuminated and the user requirements.
- Lighting should also be used as a wayfinding technique to provide a clear and distinct path from roads, walkways and parking lots to entries.
- The use of high efficiency lighting equipment, sensors, timers and other energy efficient measures to minimize energy use is encouraged.
- To minimize night pollution and unnecessary glare, exterior lighting shall be appropriately oriented and shielded.
- Spaces utilized for passive and active recreation should incorporate sufficient lighting for usability and security purposes.



*Pedestrian pathways shall be properly lit (i.e. bollard lights)*



*Parking lot lighting shall use energy efficient and directed downward*



*Creative designs shall be used to enhance the project*



## I. SITE AMENITIES

Projects must be designed, whenever possible, to include an array of features to maximize opportunities to create usable, attractive, and integrated public spaces with ample amenities. Not all projects have the opportunity to provide every amenity possible, however, all projects have the potential to include some degree of site amenities. These will vary depending on the type of project and the user profile to adequately serve the scale and character of the project. Some examples of site amenities include, but are not limited to, public plazas, site furniture, pocket parks, public art, transit shelters, places for active and/or passive recreation, landscape features, trash receptacles, arbors, and lighting. Site amenities are important as they make the user feel welcome and create a sense of place that can be utilized for social interaction, or a place to relax and unwind.

### I.I. PLAZAS

- Public plazas should be accessible from sidewalks and pedestrian pathways.
- Plazas shall incorporate some form of site furniture to provide a space for the user to congregate and relax in the space. Site furniture may include benches, picnic tables, or low retaining walls that double as a place to sit.
- Attention should be placed on the landscaping to ensure adequate shade and/or shelter is provided for the user to be protected from weather conditions.
- A change in paving material or a change in color to the paving should be incorporated to differentiate the plaza from the pedestrian paths leading up to the plaza.
- Materials used for various site amenities should be of at least equal quality as the materials used for the primary buildings and landscaping on the site.



*Incorporate site furniture such as benches and shade structures*



*Incorporate a change in paving or color to differentiate the plaza*



*Public amenities shall be provided and accessible by all uses*



*Fountains are a good way to create a focal point and create a sense of place*

## I.II. SITE FURNITURE

- Site furniture such as benches, trash receptacles, and arbors should be complimentary to the character of the development.
- Furniture selection and design should take into account weather effects such as sunlight, expansion and contraction, wind stress, and moisture.
- Site furnishings shall not be a hazard for pedestrian or vehicular traffic. Their placement should enhance the circulation and not be obtrusive or be an obstacle to the path of travel.
- Furniture items designed for outdoor spaces must be constructed of safe, durable materials and designed to prevent injury, without sharp edges or exposed fasteners.
- The type of furniture and its arrangement should take into account visibility and sightlines, lighting, and accessibility issues that may be faced by a variety of users such as children, the elderly and the disabled.
- Waste receptacles should be highly visible and accessible in order to minimize littering.
- Amenities that may fall victim to vandalism should be secure and clearly visible from multiple areas of the site.

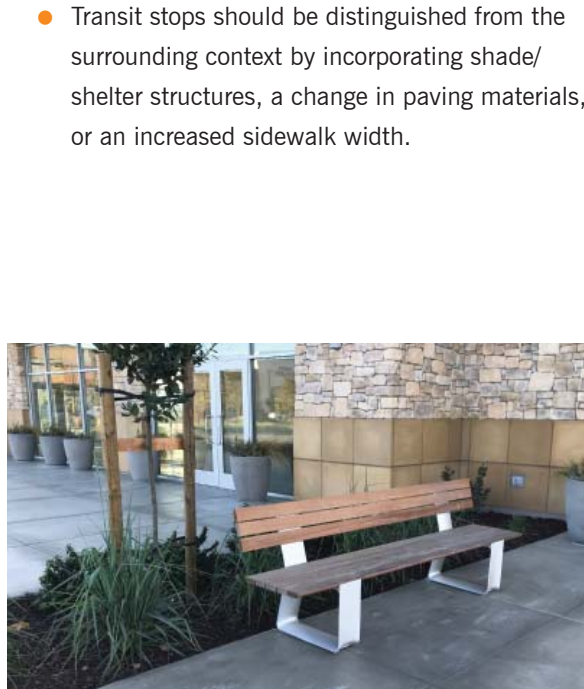

*Site furniture shall be made of durable materials*



*Site furniture should be complimentary to the character of the development*



*Type of furniture should take into account visibility, lighting, and accessibility issues*



*Site furniture must be functional and aesthetically pleasing*



## J. ADDITIONAL DESIGN GUIDELINES FOR SPECIFIC TYPES OF NON-RESIDENTIAL DEVELOPMENT

The following sections outline additional guidelines that are specific to Retail Commercial Centers, Business Park and Light Industrial developments. Any project that falls into one or more of the previously mentioned categories must follow the Guidelines outlined in the previous sections as well as the Guidelines in the following section.

### J.I. RETAIL COMMERCIAL CENTERS

- Commercial centers should be designed with careful consideration to the location, placement and orientation of buildings relative to the street and one another. Where possible, multiple buildings should be clustered to achieve a “village scale”. This creates opportunities for plazas and pedestrian areas while preventing long “barracks-like” rows of buildings.
- Commercial centers should avoid long linear buildings. Instead, they should incorporate breaks between buildings to provide visual relief. This may be achieved through change in material, mass, height, articulation of facade or, change in roof planes etc.
- Where parking is located in the rear or on both sides of the building provide breaks in the building to allow for pedestrian connections.
- Landscape areas, outdoor plazas and seating areas should be integrated into pedestrian connections providing opportunities for buildings to orient, and address outdoor spaces.
- Buildings are encouraged to provide an entrance and/or windows facing the street. When this is not possible, the building façade should be designed with enhancements addressing the street which may include real and/or faux windows, awnings/pedestrian arcades, outdoor seating/public plaza, landscape features/ plantings, or other design elements.
- Where a side or the rear of an commercial building abuts the landscape corridor along the adjoining street(s), the building architecture should be articulated and detailed so that there is sufficient visual interest and does not appear to be backing on to the corridor.
- A visual link should be established between buildings with the use of an arcade system, trellis, colonnade, enhanced paving, building articulation and detailing, or similar features.
- Outdoor areas for gathering or dining are encouraged. Where incorporated, outdoor dining areas should be used to bring activity to plazas/ courtyards, and should be placed at the edges of open space, or located along building and street frontages.
- Outdoor dining areas should be oriented away from off-site uses that are sensitive to noise or nighttime activity.
- Storefront areas should incorporate significant landscaping (including canopy trees). Frontage design and signage locations should be coordinated with the placement of plant materials to ensure plantings do not obstruct visibility of signage in designated locations.
- Commercial uses, such as auto repair, service stations, car washes, and fast food drive-throughs should be oriented so the service bays and drive through aisles are not oriented to the primary street frontage. Where such facilities

do face an adjoining street, screening through the use of berming or mounding of the earth, planting of shrubs or tall ground cover, low walls, or other decorative feature may be used.

- Where provided, shopping cart return areas located in parking lots should be adequately spaced, conveniently located and integrated within pedestrian connectors to encourage their use and avoid conflicts with vehicle circulation.
- Use of smaller liner shops should be utilized to reduce the scale and the mass of big box buildings.
- When applicable, big box buildings should integrate outdoor areas that accommodate lower buildings or pedestrian scale architectural elements, such as an outdoor garden supply area in a hardware store or an outdoor eating area for a grocery store.



Shopping cart return areas should be conveniently located



Minimize the scale of the building by breaking it up into smaller shops



When backing onto streets, enhancements may include awnings, trellises, faux windows



A visual link between buildings shall be provided, in this case a trellis



Outdoor areas for dining and gathering are encouraged



Storefronts should incorporate significant landscaping that coordinates with storefronts



## J.II. BUSINESS PARKS

- When developed as cluster of buildings, the development should focus on creating a “village” where a cluster of buildings are arranged around a common pedestrian scaled amenity or circulation element and the parking is located in smaller fields behind the buildings. In such developments effort should be made to create a coherent architectural vocabulary between the different buildings.
- Parking areas along major public streets should be screened by buildings or landscape.
- The development should have an integrated palate of signage, outdoor furniture, and lighting fixtures that are compatible to each other, the architecture of the buildings and the overall character of the project.
- Integration of plazas and gathering spaces connected by pedestrian walkways as central focal elements of the development is strongly encouraged.



*Example of a Village created around a cluster of buildings*





Site location maps are a good wayfinding technique



Integration of gathering space as a central focal element



Wayfinding may be integrated to be functional and add to the overall character of the project



Incorporate public gathering spaces



Integrate areas for recreation (i.e. volleyball court)



Clearly define building locations



### J.III. LIGHT INDUSTRIAL

Generally, guidelines for industrial development are intended to protect adjoining uses from excessive noise, odor, objectionable views and unrestricted vehicular circulation. Sound industrial site development practices include controlled site access, service areas located at the sides and rear of buildings, convenient public access and visitor parking, screening of storage, work areas, and mechanical equipment, storage and service area screen walls, and an emphasis on the main building entry and landscaping. The following guidelines apply to the light industrial development.

- Integrated development of industrial projects are strongly encouraged and shall be designed with functional relationships between buildings using similar architectural styles and a system of usable indoor and outdoor public areas.
- New industrial development should build upon the established development pattern of the surrounding area reinforcing the relationship to the public realm and the circulation pattern.
- Light industrial developments should feature enhanced pedestrian area(s) such as plazas, patios, courtyards, linear promenades, walking/jogging paths, terraces, or usable landscaped areas.
- Landscaping shall be used to soften sides and backs of buildings visible from walkways and public streets.

- While business and light industrial parks may primarily be served by vehicles, attention should be given to the pedestrian environment, including provision of sidewalks, planter areas with both low vegetation as well as trees to buffer from vehicles and provide shade.
- Signage should be appropriately located and sized so that they are visible to both vehicles and pedestrians.



*Signs should be visible to pedestrians and vehicular traffic*



*Pedestrian pathways should be integrated into the project*



*Landscaping shall be used to soften the mass of the building*

## 5.2 ARCHITECTURE FOR NON-RESIDENTIAL DEVELOPMENT

*The following sections are guidelines that pertain to the exterior of non-residential buildings, as well as the relationship of the buildings to the surrounding build context. The Guidelines herein are intended to supplement the minimum development standards in the Zoning Code. Design concepts listed below represent the City's desired characteristics for non-residential architecture:*

- *Promote high quality building designs that are visually welcoming.*
- *Is constructed of durable and high-quality material that is attractive and will contribute to the longevity of the building.*
- *Ensure building design achieves human scale and interest.*
- *Ensure the design of proposed buildings or structures is sensitive to the neighborhood character with regard to scale, architectural style, use of materials and bulk.*

### A. ARCHITECTURAL STYLE AND CHARACTER

It is the goal of the City that the following Guidelines ensure a quality of architecture that complements the community setting and character and contributes to its aesthetic and visual quality. The intent of the architectural Guidelines is to encourage projects that fit within and contribute to the established or planned architectural character and context of a specific area.

- New buildings should be compatible with the surroundings. In some locations with established architectural identity this may be a continuation or a version of an established theme. In other areas, compatibility may be addressed through issues of scale and character that is envisioned for the area in the future.
- In projects with multiple buildings there should be stylistic or a thematic architectural character that ties the individual buildings, especially the facades together. This can be achieved in two ways:
  - Using a similar visual theme, materials and elevation character for all buildings.
  - Using a more innovative interpretation of the theme, such as using similar hues or materials, using cues of scale and elevation profiles of existing structures but interpreting it in a newer, contemporary look.
- Where a new corporate tenant needs to be integrated within an existing development with an existing prevalent theme, the proposed corporate tenant should take cues from the existing development and create a style that blends the corporate architecture with the local theme creating an architectural style that is a blend of both. For example new developments with corporate branding may take cues from the surrounding development for the base colors while incorporating the corporate colors, materials and branding as the foreground or accent.



## 5.0 Non-Residential Development

- Primary entries should be located on major pedestrian pathways to provide clearly visible pedestrian access, while secondary entries may be located at the side or rear of the building.
- Entries shall be clearly defined with signage and architectural details.



*Architecture shall include high quality materials*



*Architectural materials and colors should be consistent with the theme of the building*



*Entries shall be clearly defined through signage and architectural details*



*Incorporate similar scale, mass, and character to create a cohesive look*



*A prevalent theme should be apparent throughout the project*

## B. MASS, SCALE, AND FORM

Architectural scale, for purposes of these Guidelines, is the relationship between the size of the new buildings and the size of surrounding buildings. Scale also refers to how the size of the building relates to the size of a human being (human scale). The apparent scale of a building should be reduced through the proper use of window patterns, roof overhangs, equipment bays that screen unsightly elements, awnings, moldings, fixtures, the use of darker or subdued colors, upper story setbacks, building and roof articulation and other details.

- Design all proposed buildings or structures to be sensitive to the neighborhood character with regard to scale, architectural style, use of materials, and bulk.
- Large buildings should give the appearance of smaller components through features such as recessed facades and articulation in the building mass, stepping down of edges, incorporation of human scaled elements along entries and walkways.
- Detailing, such as furring, score lines, battens, reveals, and wainscots that help break the visual mass of the large walls appropriate to the architectural style of the building should be used.
- Long blank unarticulated facades shall be avoided. Building facades should be designed with sufficient articulation, fenestration, architectural treatments such as trellises or canopies, change in materials and color to break them into smaller visual elements.
- Variation in roof planes and forms and change in parapets heights on long monotonous building forms are encouraged to create visual interest and a more dynamic skyline.
- Projects with multiple buildings should have some variation in setback, roof planes, wall planes, or other adjustments such as use of arcades and covered walkways to avoid a monotonous or overpowering institutional appearance.
- Buildings should not be simple boxes. Roof form, mass, changes in plane such as by furring, moldings, shapes, and materials should be used to create variation and visual interest. Variety in architecture elements and colors, compatible with the architectural style of the building, is encouraged.
- Buildings shall be designed to break the mass into smaller scale components vertically by incorporating a distinct base, a middle and the top to the building design:
  - The base may be low planters and walls, base planting, a base architectural veneer banding (wainscot), or change in material, texture, or color. The base may also be achieved by the addition of intermittent covered walkways, trellises or architectural awnings that provide deep shadow at ground level.
  - A well-defined top can be achieved by using multiple architectural roof forms, clearly pronounced eaves, and distinct parapet designs and cornice treatments that create a visually interesting skyline.
- Design building entries and street side facades with elements that enhance pedestrian comfort and orientation while presenting features with visual interest that invite activity.



## 5.0 Non-Residential Development

- Canopies, awnings, arcades, and overhangs are encouraged over window displays and entries along frontages of commercial buildings. Canopies, awnings, and arcades should be proportional to the scale of the building in terms of size and shape, and should be compatible with the architectural style of the building.
- Projects at defined nodes or gateways are encouraged to provide prominent visual landmarks such as a tower element, promenade, arcade, or other pedestrian-oriented feature. These elements can help create wayfinding and a distinct sense of place.
- The scale of building(s) on a site edge should respect the scale of the adjoining development. Where surrounding development is of a small scale, large-scale buildings should be located away from the edges, be sufficiently setback or transition in scale to address issues of urban form, transitional scale, compatibility and privacy.



*Large buildings should give the appearance of smaller components*



*Roof form, mass, changes in plane should be used to create variation*



*Tower elements should be used at gateways to create a sense of place*



*Architectural features shall be used to break up long blank walls*



*Canopies, awnings, arcades and overhangs are encouraged over windows and doors*



## C. ARTICULATION, FENESTRATION AND WINDOWS

- Projects shall be designed to respect the privacy of surrounding uses. Upper story windows and terraces should minimize direct views into adjacent single-family yards. Options may include additional landscaping between uses, architectural screening elements, use of spandrel glazing or limiting windows on building sides which abut residential uses.
- To prevent the building from having a flat façade, incorporate awnings, canopies, or other form of window treatment where possible.
- Changes in plane such as furring, moldings, shapes, and materials shall be used to create variation and visual interest.
- Long facades shall be designed with sufficient building articulation to break up into smaller elements. Long expanses of uninterrupted wall area shall be avoided.
- Unarticulated and windowless walls are discouraged. Where windowless walls are not able to be located landscaping, and architectural treatments such as score lines, enhanced cornice details, insets, or trim should be incorporated into the design.



*Use landscape and architectural treatment to on windowless walls*



*Expanses of uninterrupted wall shall incorporate architectural elements*



*Changes in plane such as furring, moldings, shapes and materials shall be included*



*Architectural elements shall be included to eliminate flat facades*



## D. ENTRIES AND DOORWAYS

Entry features are an important aspect to providing the user clear direction to gaining access into the building. They shall be clearly visible to pedestrians and provide an opportunity to add visual interest to the architecture. The following additional design provisions apply to all non-residential development:

- Building entries shall be clearly defined and within the same scale of the proposed project.
- Primary entries shall relate directly to the street frontage to provide clearly visible pedestrian access wherever possible.
- Secondary entries may be located at the side or rear of the building or adjacent to nearby parking areas.
- Entries and doorways shall have a form of relief from natural elements. Relief may be in the form of awnings, trellises, canopies, or overhangs.
- Addresses shall be clearly defined and located within close proximity to all primary entries.
- The size of the entry shall be proportional to the scale of the building.



*Entries shall be clearly defined and within the same scale of the project*



*Addresses shall be located within close proximity to all primary entries*



*Primary entries shall relate to the street or nearby parking*



*Entries and doorways shall have a form of relief from natural elements.*



*The size of the entries shall be proportional to the size of the building*

## E. MATERIALS AND FINISHES

Exterior building materials and colors comprise a significant part of the visual impact of a building. The intent of this guideline is to promote high quality developments built with durable materials that promote longevity of the structure and provide a pleasing appearance as the materials and the buildings age.

- Materials, colors, details and finishes shall be appropriate to the architectural style. Use of accents to complement the architecture, highlight entrances and provide visual interest is encouraged.
- Selected materials and finishes should be reflective of the use, type of buildings, anticipated target tenant, functionality, and the character of the proposed building.
- Colors and materials used should complement each other and be used break up the massing of large building facades.
- Where possible, especially in infill locations, the proposed materials and colors of a project should be based on the surrounding developments of similar use and scale. New developments with corporate branding should take cues from the surrounding development for the base colors while incorporating the corporate colors, materials and branding as the foreground or accent.

- Materials and detailing used on the front or main building elevation should be extended to all facades facing parking lots, streets, and other public areas.
- Use of durable, high quality materials such as brick, stone, tile, and certain forms of concrete are encouraged. These materials should be able to withstand climatic changes especially on the south and west elevations.
- Change in materials, color and finishes should take place at logical termination points such as change in planes, inside corners.



*Use of materials shall be consistent with the architectural style*



*Buildings shall incorporate high quality materials and finishes*



*Colors and materials should compliment one another*



*Colors and materials should be used highlight entrances*



*Color and material should be used to break up the massing of the building*



## F. SIGNAGE

Sign type, size, and location for non-residential development shall comply with applicable sign provisions in the Zoning Code. The following additional design provisions apply to all non-residential development:

- Project signage should be consistent with the architectural theme of the project.
- Signs should be in areas of the architectural façade planned for signage and constructed of quality weatherproof materials consistent with the design theme of the building or project.
- Signage should be designed for its effect both during the day and at night. Sign lighting should be directed to the sign to avoid glare and harshness.
- Signs may be used to create a distinct business identity. Unique, sculptural, one-of-a-kind signs that are encouraged.
- Artistic use of neon in surface mounted, blade or hanging and window signs is permitted.
- Franchise signage is strongly encouraged to be incorporated into a more unique design execution than an “off the shelf” standard sign, especially where a franchise is being integrated within an existing development or neighborhood with a distinct character.
- The City encourages the use of signs that

incorporate channel letters, push through/routed signs. Poles and canned signs are discouraged. Use of such signs may be evaluated on a case by case basis as a part of the Design Review application.



*Signage materials shall be consistent with the architecture*



*Example of a canopy sign*



*Example of a channel letter sign*

## G. BUILDING LIGHTING

Lighting on buildings and sites can have a dramatic effect on the mood, quality, and character of commercial districts. The color, intensity, and types of lighting used contributes to the character of commercial areas. Adequate and carefully placed building lighting in conjunction with lighting on the site and surrounding streets can improve the safety and security.

- All exterior light fixtures shall be compatible with the architectural character development.
- Lighting used to accent an architectural feature or design attribute may be approved in conjunction with Design Review.
- Lighting shall be used to highlight building entries
- All exterior building lighting shall be appropriately sited based on the location and the use of the area to be lighted.
- Exterior building and site lighting shall be designed so that light is not directed off site and the light source is shielded downward from direct off-site viewing.



*Lighting shall be used to highlight building entries*



*Example of a light that has light directed downward and upward*



*Building lights shall be compatible to the architectural style of the building*



*Example of a light that is directed downward*



## H. ADDITIONAL GUIDELINES FOR SPECIFIC TYPES OF NON-RESIDENTIAL DEVELOPMENT

The following sections outline additional architectural design guidelines that are specific to Retail Commercial Centers, Big Box Retail, Business Park, and Light Industrial developments. Any project that falls into one or more of the previously mentioned categories must follow the Guidelines outlined in the previous sections as well as the Guidelines in the following section.

### H.I. COMMERCIAL CENTERS

- To avoid flat facades exterior walls shall vary in depth (recessed or projected) or direction.
- In order to break up the apparent mass of the building rooflines shall vary.
- Facade articulation shall be provided through the use of color, arrangement of façade elements, or changes in material.
- Facade shall include reveals, recesses, projections, cornices, trim elements and other architectural features to provide visual interest.
- Long, blank walls at the ground floor level should be avoided. Windows, trellises, wall articulation, arcades, changes in material and other features should be incorporated to help provide visual interest.
- Landscaping should be provided at the base of the building to soften the appearance.
- The pad building design should be compatible with and reflect the planned architectural style or theme of the commercial center.
- Service station islands or other open canopies should be integrated architecturally and compatible with the character of the building(s) on the site (e.g., column and canopy design should match the architecture and building treatments of the main structure).



*Rooflines shall vary to break up the building mass*



*Blank facades should be avoided through change in planes, materials, colors, and landscaping*



*Service station canopies should compliment the building character*

## H.II. BIG BOX RETAIL

Building design shall meet the standards set forth in EGMC 23.74 Big Box Design Standards. The Guidelines below are in addition to the standards set forth in that chapter.

- A variety of colors and materials shall be used to prevent large monolithic boxes.
- The big box building should contain an identifiable base where the building meets the sidewalk or faces a parking lot or street.
- The base articulation shall extend at least two feet in height and is intended to visually ground the building and soften the visual mass of the vertical wall plane. Articulation may include a change in surface texture, wall color, material, or other improvement that meets the intent of the guideline.
- A variety of roof types are encouraged.
- Distinct and interesting parapet tops on predominantly flat roofed structures are encouraged.
- Pitched roofs should be multi-planed to avoid large expanses of monotonous single-planed roofs.
- When flat roofs are used, there should be a screening parapet topped with a coping, cornice, or a modified mansard. Parapets should vary in

height to break the roof line and to create visual interest.

- Mansards should maintain the same roof pitch as surrounding structures and shall be both high and deep enough to create the illusion of being a true roof.
- The base of the big box building should include landscape planters and/or enhanced pedestrian pathways on all sides facing a parking lot or street.
- Entries should be clearly defined and identifiable through the use of enhanced architectural treatment, change in material or color and signage.
- Cart return areas next to buildings shall be screened.



*Incorporate breaks and projections to avoid long flat facades*



*Include a variety of materials and plane changes to create interest*



*Break up the roof line by varying the height*



*Base of building should include landscape planters*



### 5.0 Non-Residential Development



*A variety of colors and materials shall be used*



*Entry highlighted through change of materials and color*



*Architectural detail should be used to define entries*



*Materials shall wrap the corners and end at a logical termination*



*Entries should be easily identifiable*



*Screen shopping cart return areas when adjacent to the building*



*High quality materials shall be used to enhance the design of the building*



### III. LIGHT INDUSTRIAL/BUSINESS PARKS

- Main building entries should be emphasized through building articulation and form so the entry is easily identified and visible from the street and parking lot.
- High quality and durable materials shall be used on all buildings.
- All industrial buildings, including pre-cast and site-cast concrete structures, should incorporate architectural detail in the form of applied finishes, integral textures, patterns, colors, three dimensional recesses and projection.
- Landscaping along streets and pedestrian walkways should be used buffer buildings from the public realm.
- The use of typical utilitarian design with exposed low pitch roof, no overhang, single color, and flat walls are discouraged.
- If a metal or concrete building is to be used, it should include such features as offsets in the wall planes, recessed entry features, metal canopies, several colors, and/or multiple siding profiles.
- All sides of an industrial building should reference consistent architectural detail and character.
- Service and loading areas should be screened from public streets.

- Wireless communication facilities should be integrated directly into the architecture of building(s) as opposed to freestanding locations.



*Architectural elements should be used to define entries*



*High quality materials shall be used on all buildings*



*Incorporate landscaping to help break up the facade*



*Colors and materials should be used to breakup the facade*



*Service areas should be screened from public streets.*



*Buildings should be appropriately set back from the public streets*





Welcome to

**Elk Grove**

A community since 1850

