

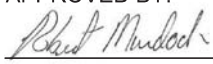

DATE 09/22/2017		NOT TO SCALE	
REVISION	BY	APPROVED	DATE
01	STN	JRW	02/16/2021

CITY OF ELK GROVE - PUBLIC WORKS

**EXTERIOR PERIMETER
PROPERTY LINE GRADING FOR
FILL AREAS**

APPROVED BY:

 CITY ENGINEER 02/26/2021
 DATE

DRAWING NUMBER
G - 1

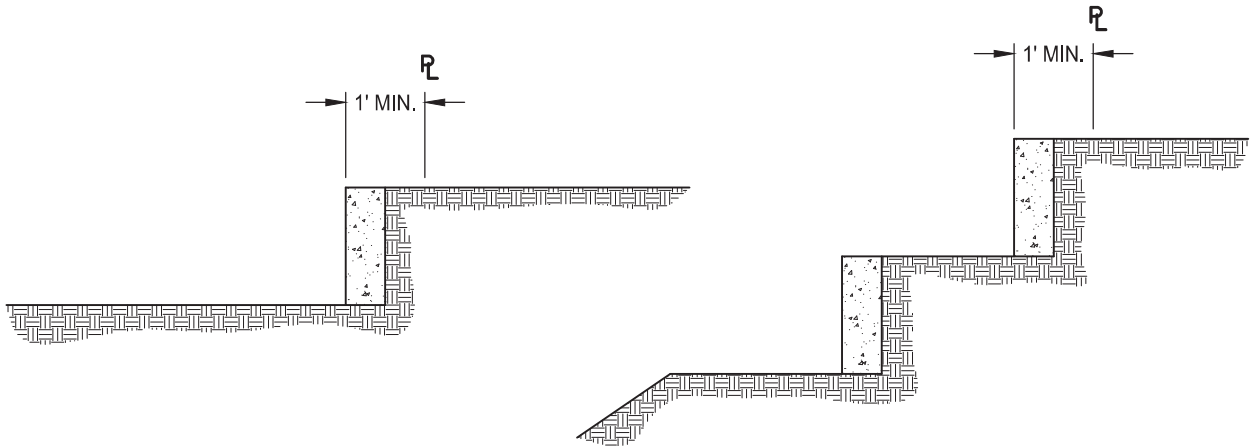
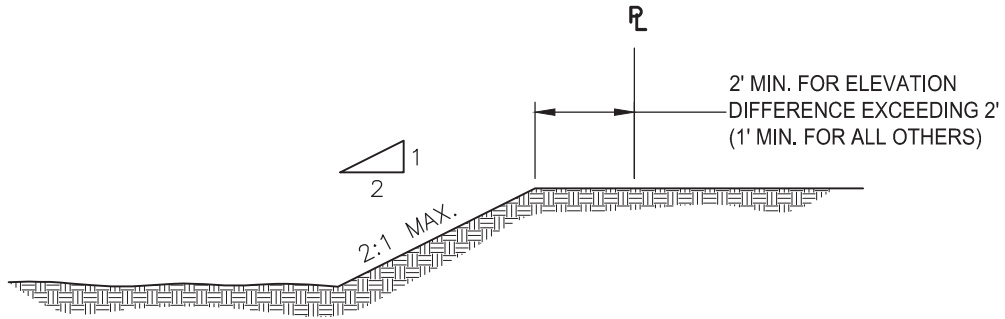



RETAINING WALL

(SEE STD DWG G-3 AND G-4)

NOTE: NO DOUBLE RETAINING WALLS SHALL BE CONSTRUCTED ON SIDE YARD

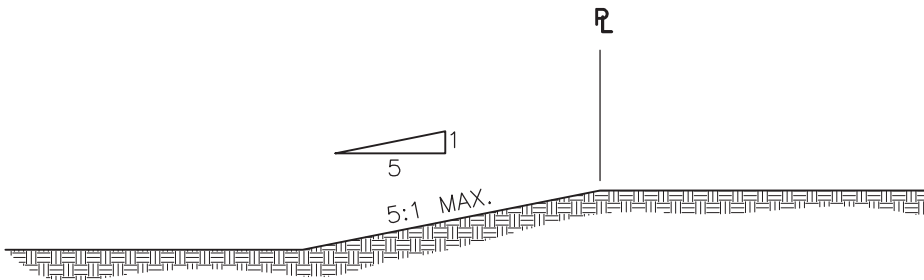

DATE: 09/22/2017		NOT TO SCALE	
REVISION	BY	APPROVED	DATE

CITY OF ELK GROVE - PUBLIC WORKS

**GRADING FOR INTERIOR
PROPERTY LINES AND PERIMETER
PROPERTY LINES IN CUT AREAS**

APPROVED BY:
Paul M. Muddoch
CITY ENGINEER

10/24/2018
DATE

DRAWING NUMBER
G - 2



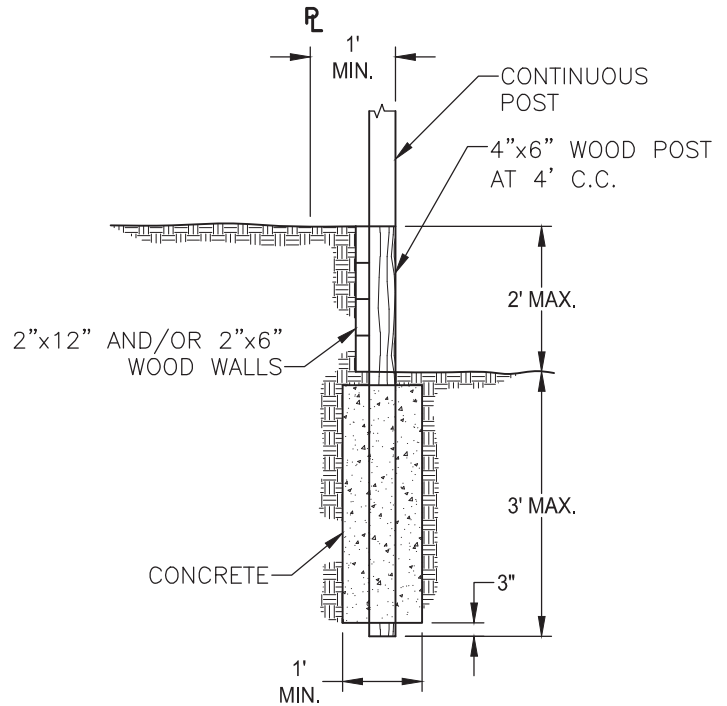
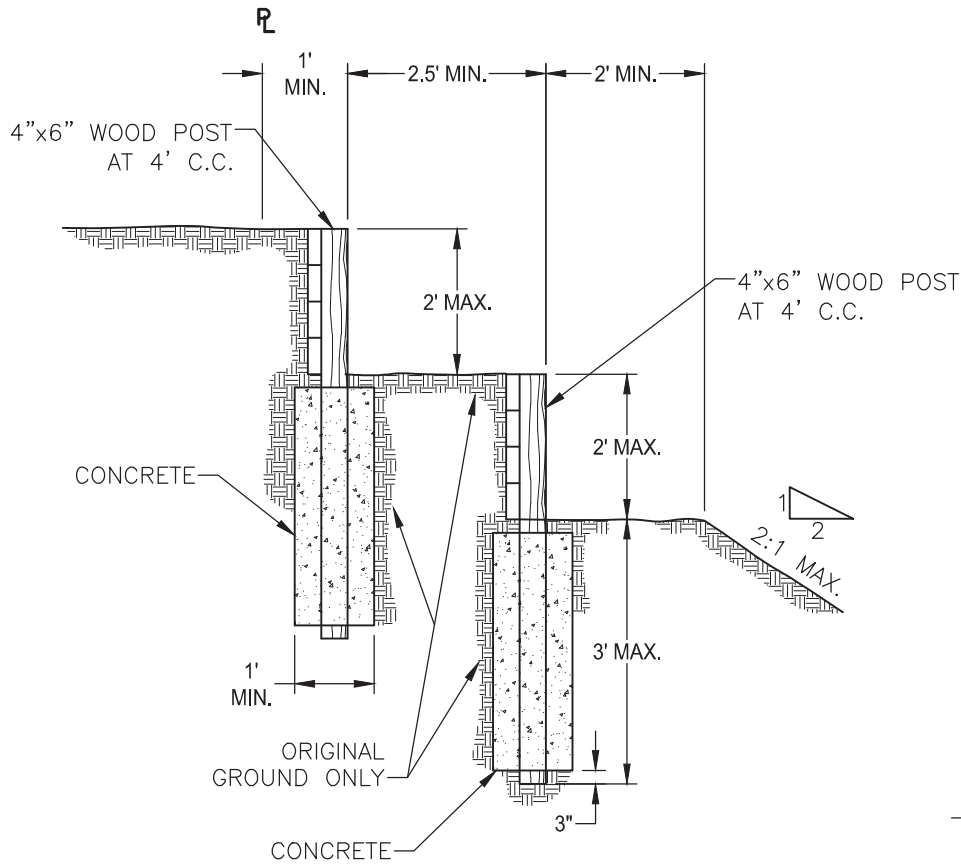

NOTES:

1. MATERIAL FOR WALLS SHALL BE GRADE NO. 2 OR BETTER REDWOOD WITH NO OPEN GRAIN MATERIAL.
2. WOOD WALLS SHALL NOT BE USED ADJACENT TO PUBLIC RIGHTS OF WAY.
3. ALL WALLS WITHIN 8 FEET OF A BOUNDARY OR PROJECT PHASE LINE SHALL BE CONSTRUCTED WITH MASONRY OR CONCRETE.
4. 4-INCH BY 6-INCH POSTS AT 4-FOOT ON CENTER SHALL BE USED AS FENCE POSTS WHEN FENCES ARE ATTACHED TO RETAINING WALLS.
5. NO DOUBLE RETAINING WALLS SHALL BE CONSTRUCTED ON SIDE YARDS.

DATE: 09/22/2017		NOT TO SCALE	
REVISION	BY	APPROVED	DATE

CITY OF ELK GROVE - PUBLIC WORKS

**WOOD RETAINING WALL DETAILS
FOR INTERIOR PROPERTY LINES**

APPROVED BY:
Paul M. Muelich
CITY ENGINEER

10/24/2018
DATE

DRAWING NUMBER
G - 3



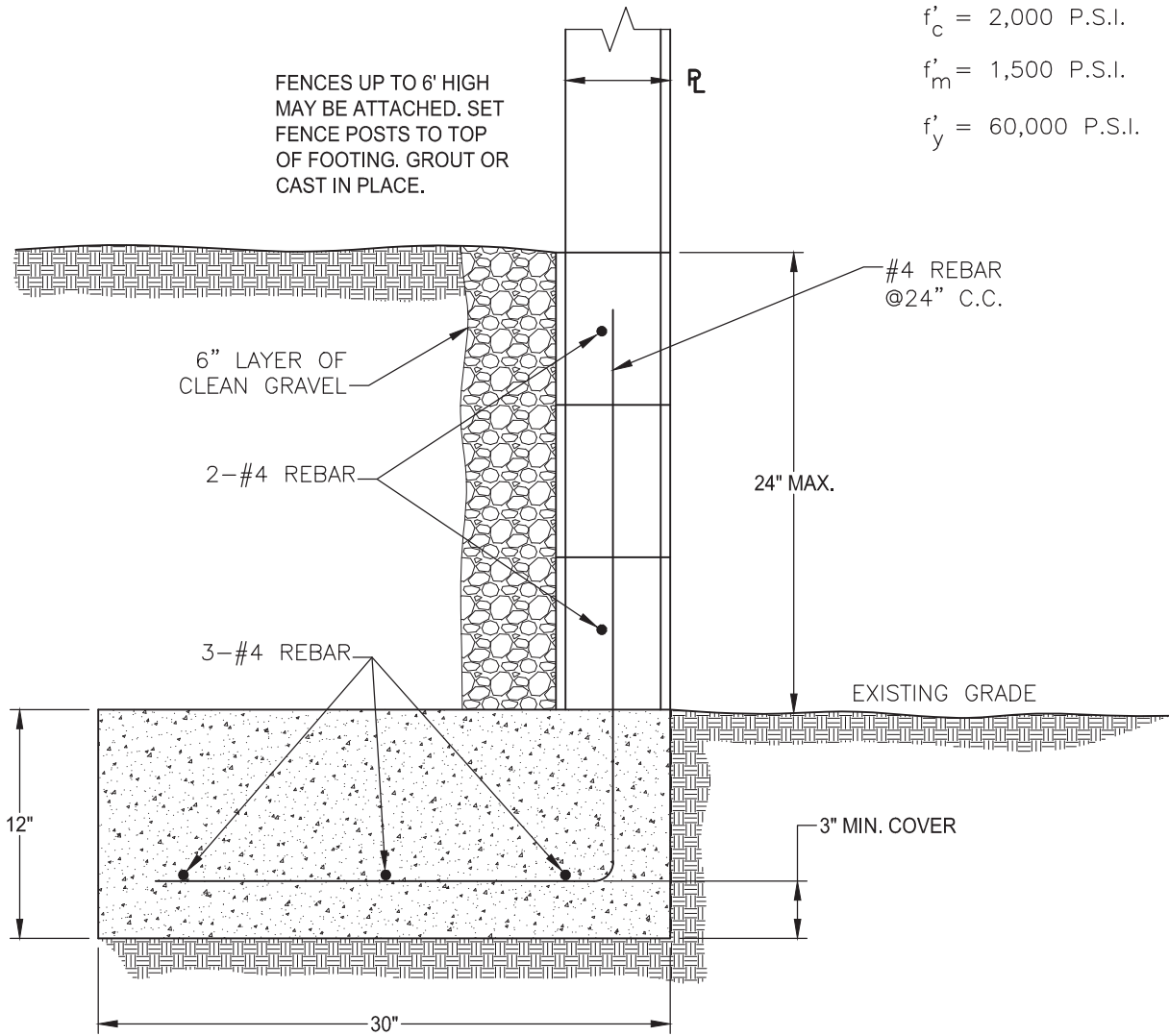

NOTES:

1. 8-INCH NORMAL WEIGHT BLOCK WITH FULL GROUTING REQUIRED.
2. A 6-INCH WIDE CAST-IN-PLACE CONCRETE STEM WALL MAY BE USED IN LIEU OF MASONRY.
3. SPECIAL INSPECTION IS NOT REQUIRED.
4. A BUILDING PERMIT IS REQUIRED FOR WALLS EXCEEDING 24" IN HEIGHT WHEN CONSTRUCTION DETAILS ARE NOT SHOWN ON APPROVED IMPROVEMENT PLANS.

DATE: 09/22/2017		NOT TO SCALE	
REVISION	BY	APPROVED	DATE

CITY OF ELK GROVE - PUBLIC WORKS

**MASONRY/CONCRETE RETAINING WALL
 DETAIL FOR FILL AREAS AT BOUNDARY
 AND PROJECT PHASE LINES**

APPROVED BY:
Paul Muddoch
 CITY ENGINEER

10/24/2018
 DATE

DRAWING NUMBER
G - 4

