

Phone: 916.683.7111
Fax: 916.691.3168

Web: www.elkgrovecity.org

8401 Laguna Palms Way
Elk Grove, California 95758



Modification or Addition to Improvement Standards and Details

Modification Number: 20090427-1

Effective Date of Change: 04/27/2009

Modification:

1. Addition of T-2B, T-2C, T-2D, and T-2E standard drawing details.

Amended specifications are attached. Projects with preconstruction conference prior to effective date not subject to modification.

Effect of Modification:

1. These new standard drawing details will provide an alternate to pre-formed rubberized speed cushion.

Request for Modification Initiated By:

Gwen Owens, P.E.

4-27-09
Date

Modification Reviewed for Conformity and Consistency to Standards:

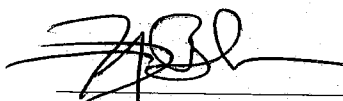

Assistant PW Director

4/28/09
Date

Modification to Improvement Standards Approved:

Director of PW/City Engineer

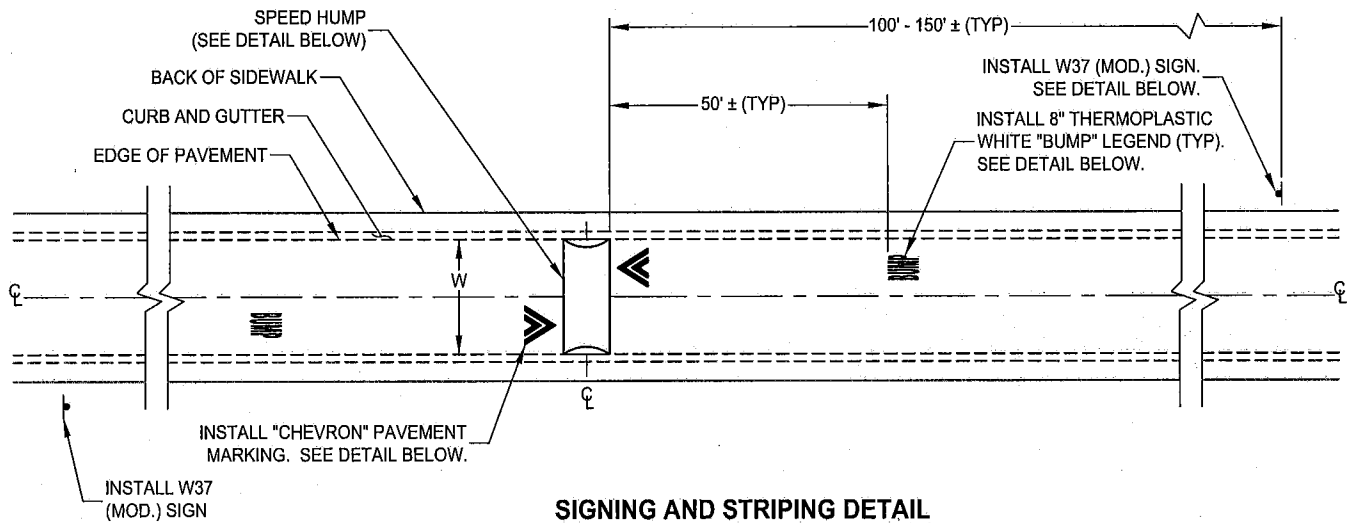
4/30/09
Date



SIGNING AND STRIPING DETAIL
NOT TO SCALE

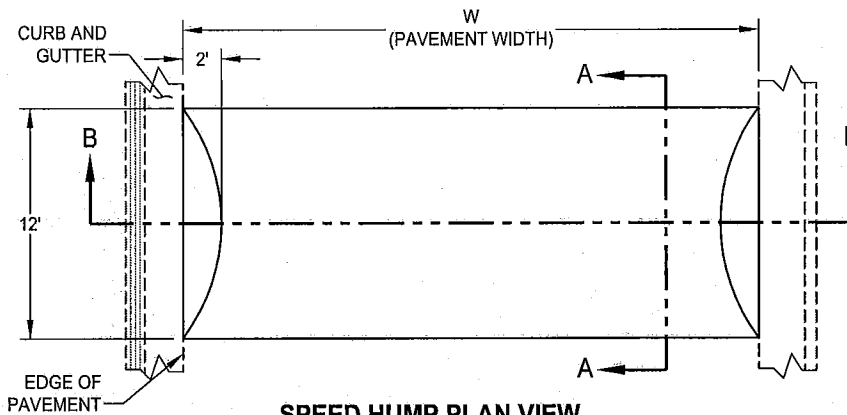

SPEED HUMP PLAN VIEW
NOT TO SCALE

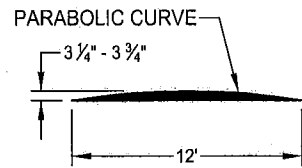

SECTION A-A
NOT TO SCALE

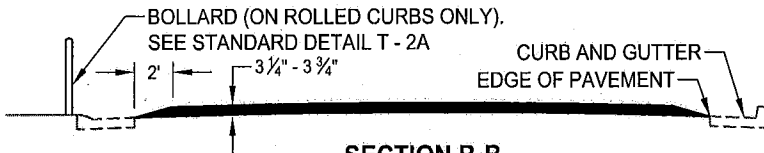

SECTION B-B
NOT TO SCALE

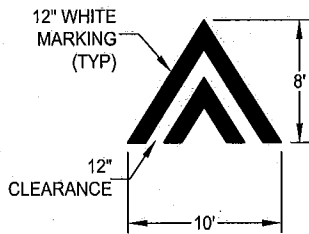

"CHEVRON" PAVEMENT MARKING DETAIL
NOT TO SCALE

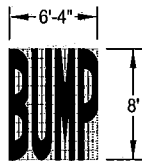

"BUMP" PAVEMENT MARKING
NOT TO SCALE

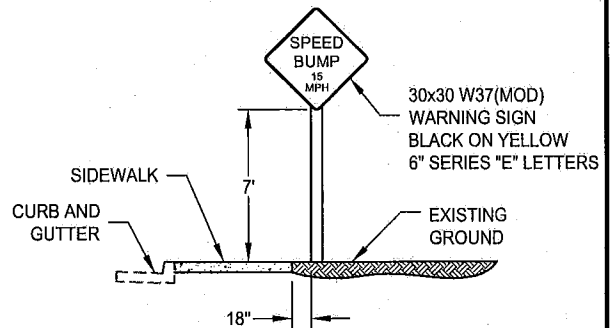

W37(MOD) ADVANCE SIGNING
NOT TO SCALE

DATE: 04/27/2009		NOT TO SCALE	
REVISION	BY	APPROVED	DATE

CITY OF ELK GROVE - DEPARTMENT OF PUBLIC WORKS

APPROVED BY:

[Signature]
CITY ENGINEER

ASPHALT SPEED HUMP DETAIL
(W = 26' - 34')



DRAWING NUMBER

T - 2B

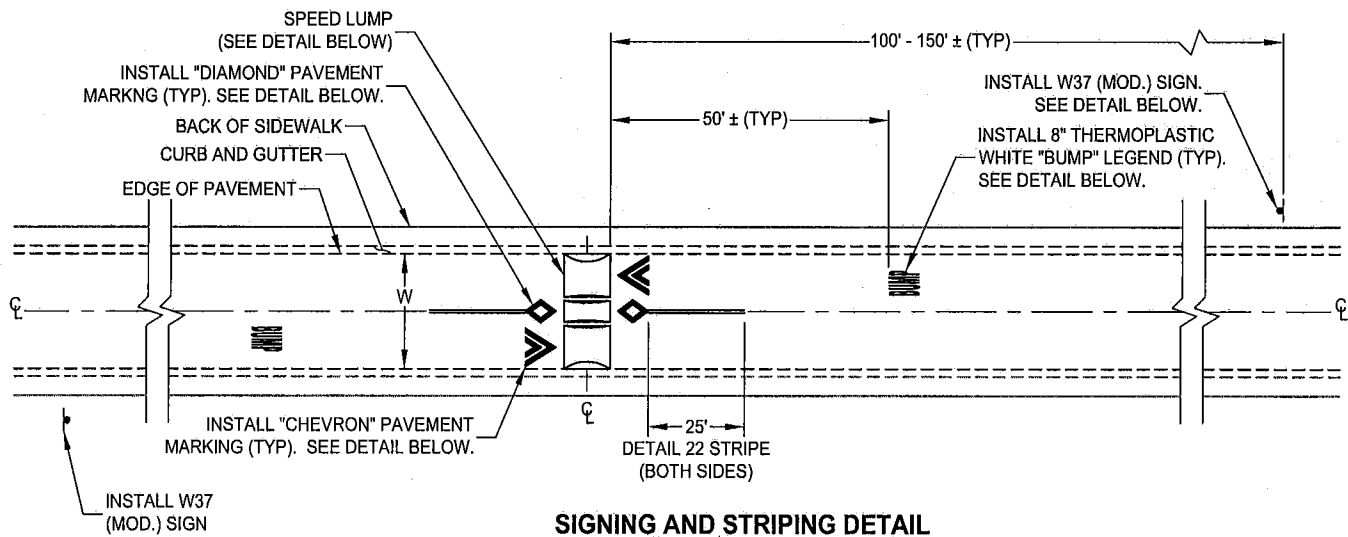

SIGNING AND STRIPING DETAIL
NOT TO SCALE

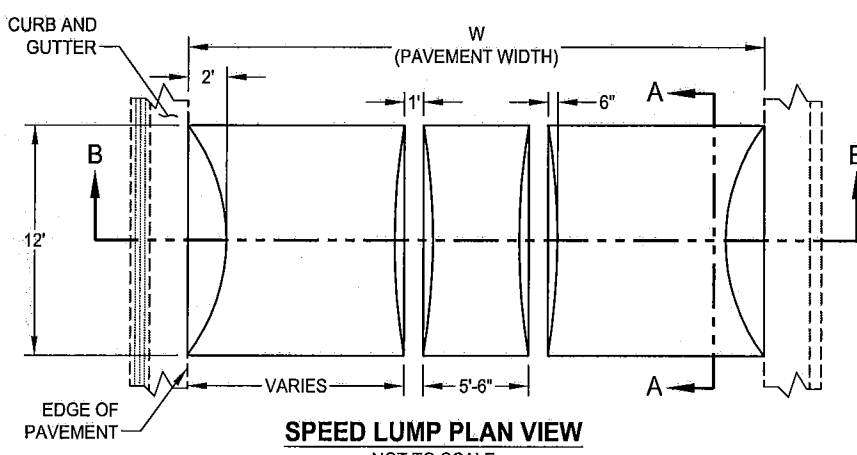

SPEED LUMP PLAN VIEW
NOT TO SCALE

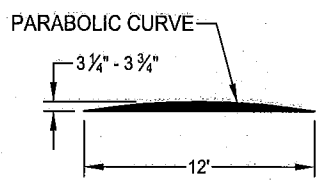

SECTION A-A
NOT TO SCALE

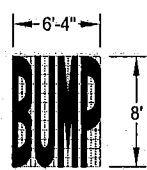

\"/>

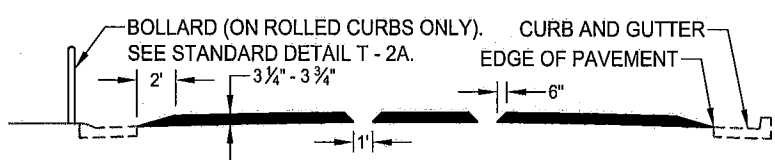

SECTION B-B
NOT TO SCALE

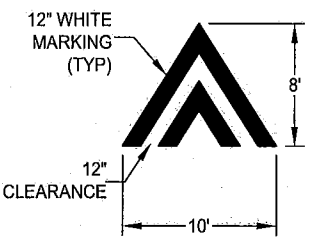

\"/>

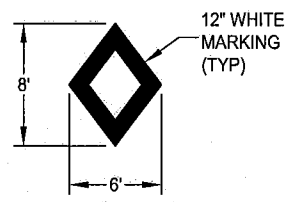

\"/>

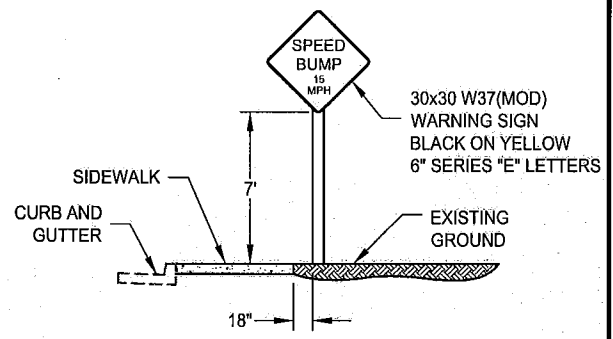

W37(MOD) ADVANCE SIGNING
NOT TO SCALE

DATE: 04/27/2009		NOT TO SCALE	
REVISION	BY	APPROVED	DATE

CITY OF ELK GROVE - DEPARTMENT OF PUBLIC WORKS

APPROVED BY:

CITY ENGINEER

ASPHALT SPEED LUMP DETAIL (1)
(W = 26' - 34')



DRAWING NUMBER
T - 2C

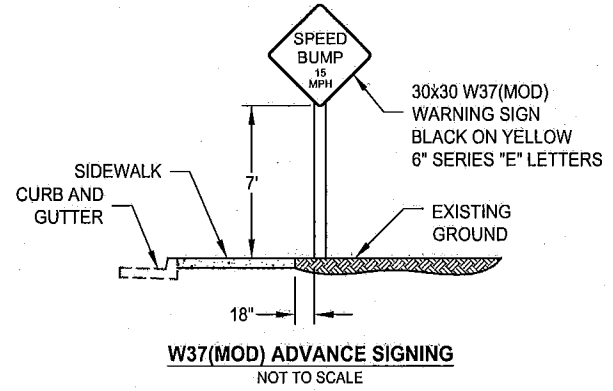
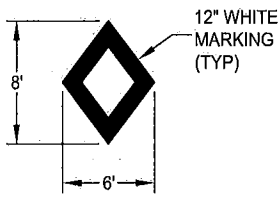
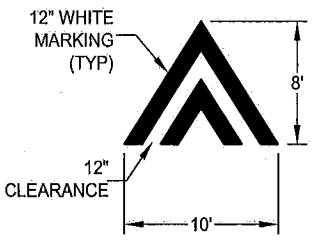
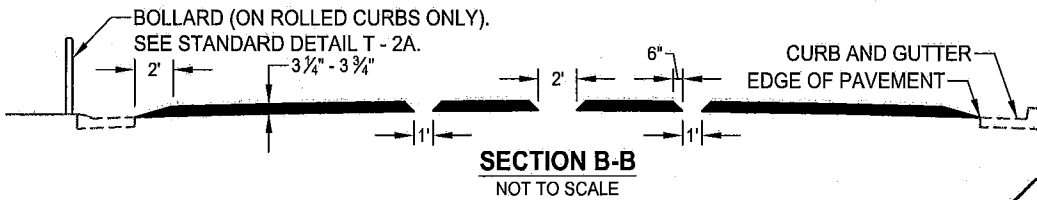
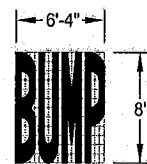
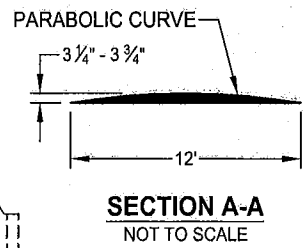
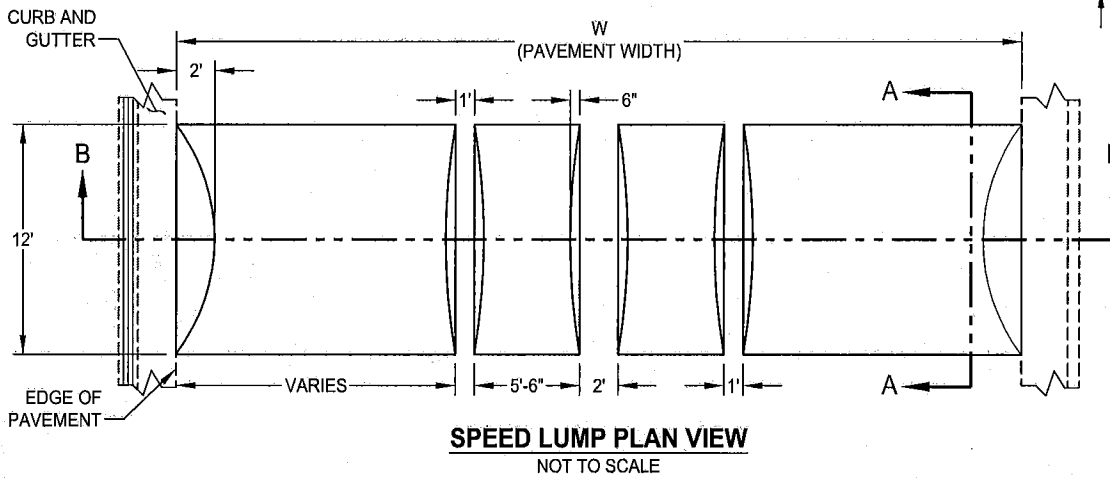
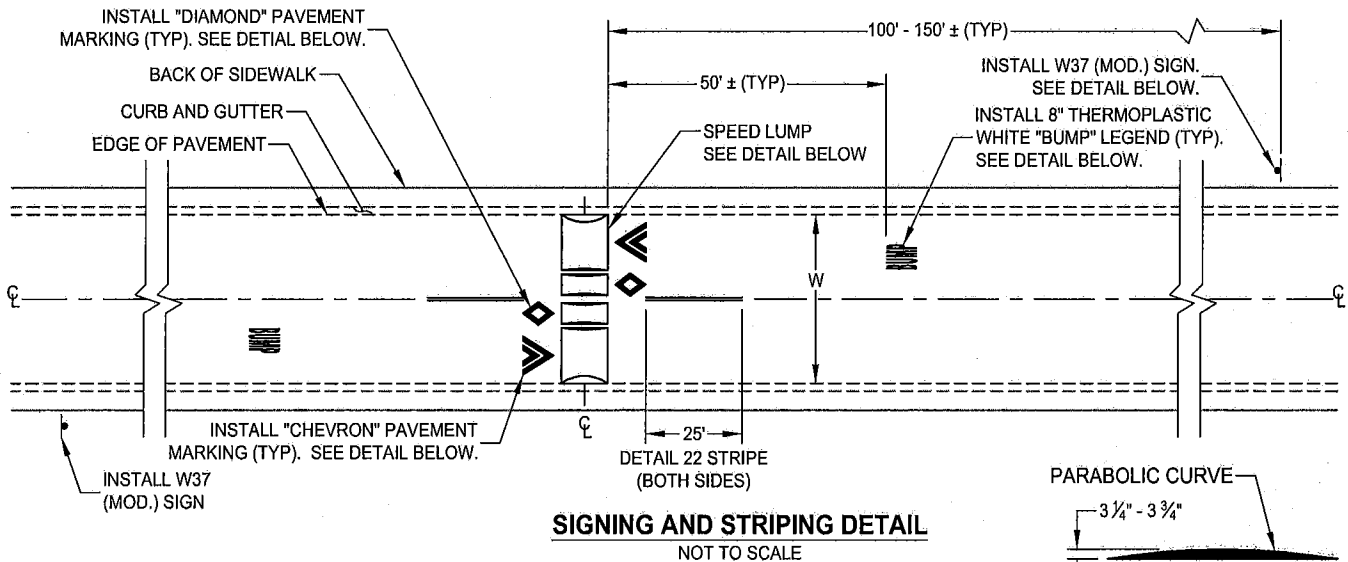

DATE: 04/27/2009		NOT TO SCALE	
REVISION	BY	APPROVED	DATE

CITY OF ELK GROVE - DEPARTMENT OF PUBLIC WORKS

APPROVED BY:

CITY ENGINEER

ASPHALT SPEED LUMP DETAIL (2)
(W = 36' - 44')

DRAWING NUMBER
T - 2D



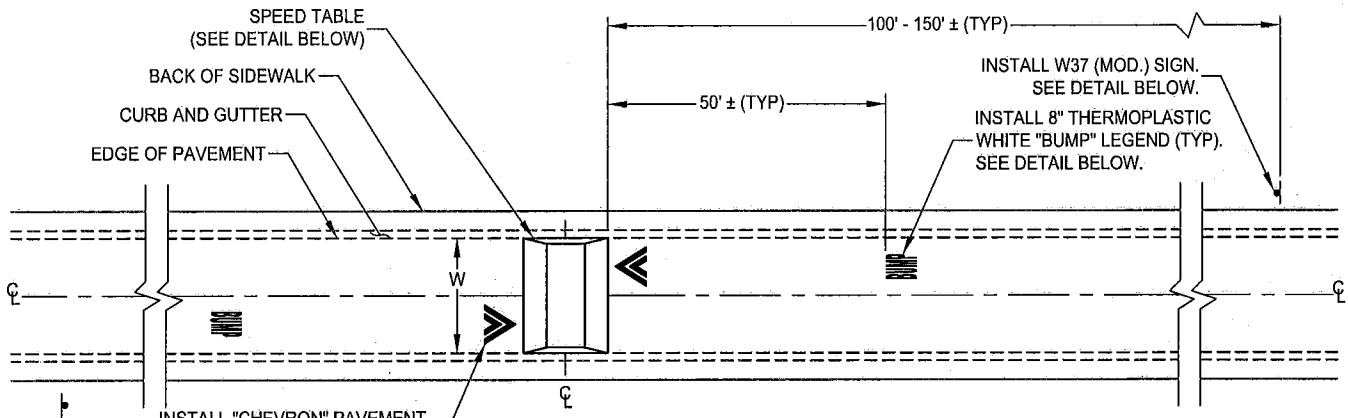

SIGNING AND STRIPING DETAIL
NOT TO SCALE

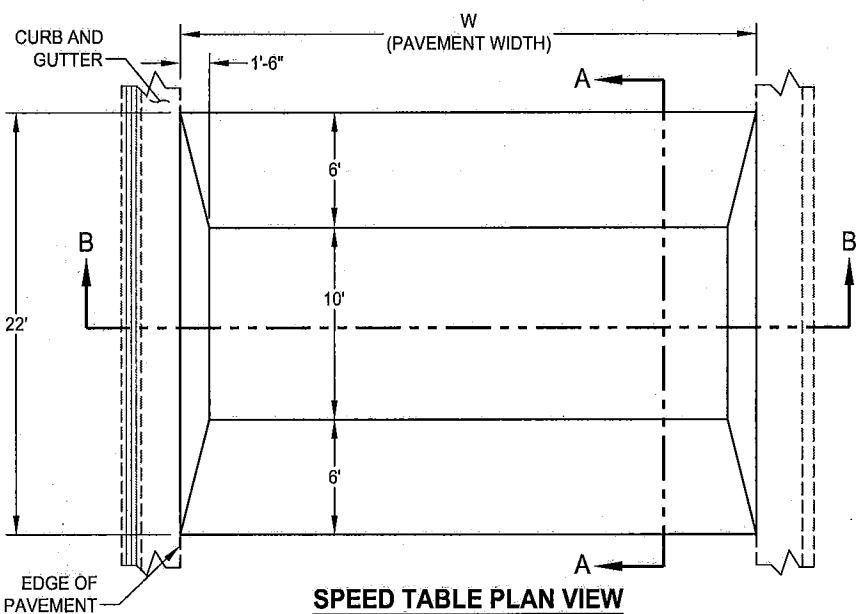

SPEED TABLE PLAN VIEW
NOT TO SCALE

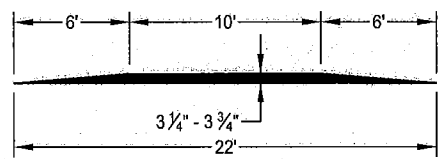

SECTION A-A
NOT TO SCALE

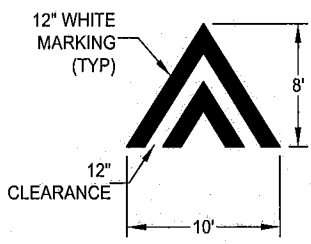

"CHEVRON" PAVEMENT MARKING DETAIL
NOT TO SCALE

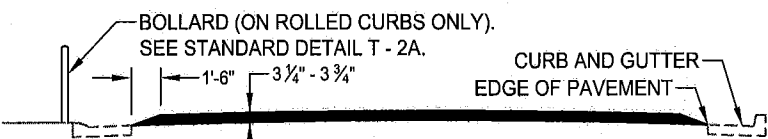

SECTION B-B
NOT TO SCALE

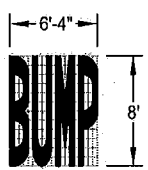

"BUMP" PAVEMENT MARKING
NOT TO SCALE

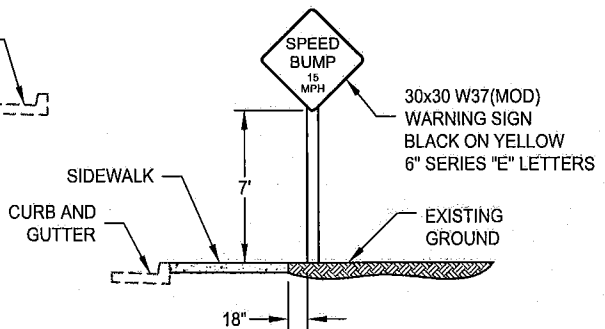

W37(MOD) ADVANCE SIGNING
NOT TO SCALE

DATE: 04/27/2009		NOT TO SCALE	
REVISION	BY	APPROVED	DATE

CITY OF ELK GROVE - DEPARTMENT OF PUBLIC WORKS

APPROVED BY:

CITY ENGINEER

ASPHALT SPEED TABLE DETAIL
(W = 26' - 44')



DRAWING NUMBER
T - 2E