

Phone: 916.683.7111
Fax: 916.627.4400

www.elkgrovecity.org

PUBLIC WORKS
8401 Laguna Palms Way
Elk Grove, California 95758



Standards Update Transmittal

Reference Number: 2024v-04
Standards: Standard Drawing, ST-42

Update:

1. Modification to Standard Drawing:
 - a. Deletes note of Type F delineator and adds "Type P (CA) (Rt) Object Marker" to barricades.

Effect of Update:

1. This modification will ensure the proper marker use for barricades at an abrupt change of pavement width.

Request for Update Initiated By: James Ashby Date

Update Reviewed for Conformity and Consistency to Standards: Shoaib Ahrary 12/18/2024 | 6:58 AM PST
Shoaib Ahrary, PE, ESD Manager Date

Update to Standards Approved: Kristin Parsons 12/18/2024 | 8:21 AM PST
Kristin Parsons, PE, City Engineer Date

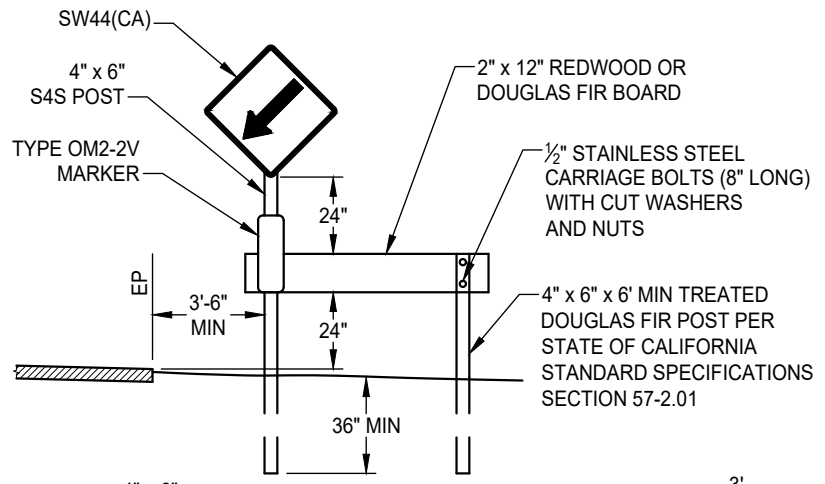
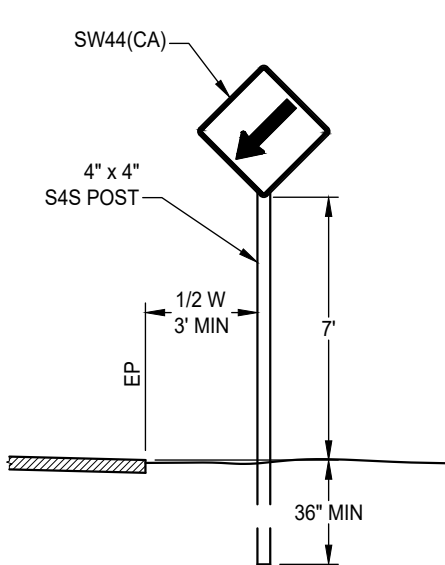

NOTE:
 1. ALL EXPOSED SURFACES OF BARRICADE SHALL BE PAINTED WITH TWO (2) COATS OF WHITE PAINT CONFORMING TO STATE OF CALIFORNIA STANDARD SPECIFICATIONS SECTION 91-3.

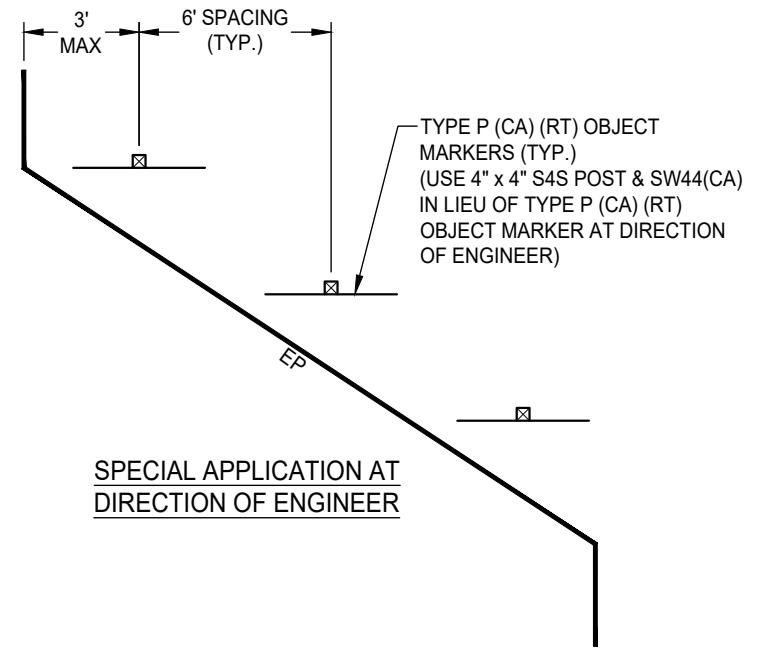
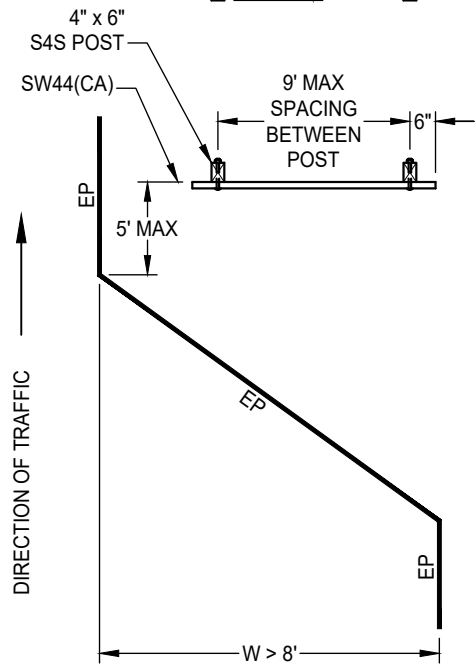
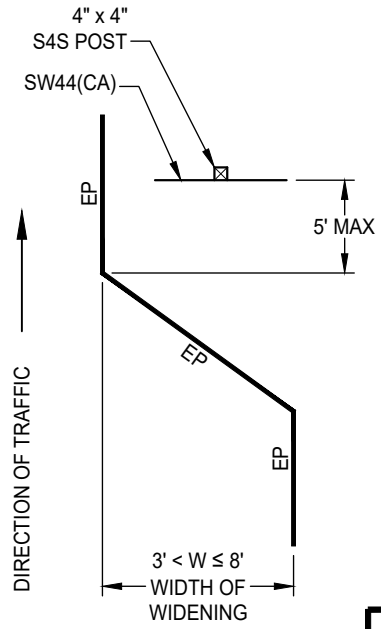

DATE: 09/22/2007		NOT TO SCALE	
REVISION	BY	APPROVED	DATE
1	SJB	SMA	07-12-2024

CITY OF ELK GROVE - PUBLIC WORKS

**SIGNS AND BARRICADES AT ABRUPT
CHANGE OF PAVEMENT WIDTH**

APPROVED BY:

 CITY ENGINEER

12-18-2024
 DATE

DRAWING NUMBER
ST - 42

